

Alphavan User Manual

Version 8.0, September 2024

Table of contents

Introduction	3	Switches in the FlexPort rear and rear doors	16
General.....	3	Switches sleeping area.....	16
Vehicle dimensions	3	Slide-Out Step	16
Environmental Information	3	Insect repellent / Fly screen sliding door.....	17
Country-specific regulations in the context of cargo on the rear, tolls and other traffic safety requirements	3	MBAC – Mercedes-Benz Advanced Control.....	17
Safety	4	MBAC Bluetooth App.....	22
General.....	4	Freshwater Tank and Drain Valve	25
Tire pressure	5	Optional (possibly additional) underbody fresh water tank	26
Snow chains	6	Watersystem: water pipes fresh water and grey water	27
Warning triangle and first-aid kit.....	6	Water pump: In-water submersible pump.....	27
Electrical Installation.....	6	Water pump: Pressurized pump.....	28
Payload and Weight.....	6	Filter System Inline.....	29
Accessories and Tires/Rims.....	7	Inline UV Water Disinfection	29
Road Safety	7	Overwintering water system and filtration system	30
AdBlue	7	Wastewater Tank/ Greywater Tank.....	30
Basic Motorhome Functions	9	Voltage Converter DOMETIC DSP 2312T for operating 230V Devices.....	31
Keys	9	Electrical operation and control center in the Alphavan	33
Admission.....	9	Air Conditioning DOMETIC FRESHJET	35
Landline Power.....	9	Refrigerator DOMETIC RC 10.4T	36
Alphavan auxiliary / living battery (LiFePO4, 210Ah) and maintaining battery performance and service life through regular charging	10	Thetford Induction Cooker	36
Alphavan furniture (Vunder Tech) and surfaces / décor	12	Heating and Hot Water- Truma Combi 6D E Heater..	37
Interior Floor	12	Frost Valve / Safety Valve / Drain Valve	40
(Swiveling) Seats and Ladder	12	Heating Operation	41
Windows and Ventilation.....	13	Electrical Awning THULE OMNISTOR 5200	41
12V Sockets	14	Bathroom / Shower	43
Overview of Switches in the Alphavan.....	15	Toilet and SOG Ventilation System.....	44
Panel over entrance area sliding door	15	Rear Outdoor Shower and Activation / Deactivation of the Water Pump	46
Switches on kitchenette in the entrance area sliding door.....	15	SAT / DVB-T TV with WiFi Connectivity, Bluetooth Support and WiFi Streaming - TV cabinet.....	47
Switches on rear wall kitchen	15	Optionally available Cellular / WiFi Router and 4G/5G/WiFi Roof Antenna.....	47
Switches on side of refrigerator.....	15	Optionally available Starlink Kit	48
Switches in the FlexPort at the storage compartments.....	15	Optionally available Display Mount for Rear Seating Area	48

Optionally available Goldschmitt HLC smart levelling system	48
Mercedes-Benz Information and Systems	50
Service, maintenance, and repair	50
Mercedes-Benz MobiloVan.....	50
Systems and Functions.....	50
Active Distance Assist DISTRONIC	50
Active Brake Assist	50
Active Crosswind Wizard.....	50
Attention Assist.....	51
High Beam Assist.....	51
Traffic Sign Assistant	51
Cruise control	51
Parking package with 360° camera	51
Hill start assistance	52
Blind Spot Assist.....	52
Lane Keeping Assist.....	52
Burglary-theft warning system	52
Multimedia system Mercedes-Benz User Experience (MBUX)	52
Mercedes-Benz breakdown call.....	53
Mercedes-Benz emergency call system.....	53
Mercedes ME connect	53
Hibernation Mode.....	54
General Recommendations for longer standstill periods	54
FlexPort	54
Safe Lashing of objects.....	54
Premium Sound System.....	55
Optional auxiliary air suspension system on rear axle	56
Appendix 1 – Energy Consumption with Active 230V Consumers	57
Appendix 2 – Placement of Fuses Model Premium Line	59
Appendix 3 – Fuse Location in Model ACTIVE LINE	60
Appendix 4 – Alphavan-specific fuse assignment in the driver's seat box	61

Appendix 5 – Emergency vests regulation and mandatory in Europe	62
---	----

Editor/Publisher:

Alphavan GmbH
Ebnetstraße 31
Germany - 88239 Wangen im Allgäu
www.alphavan.de

The publisher assumes no responsibility for the completeness and correctness of this manual and reserves the right to make changes and errors.

Duplication and publication of this publication, even in extracts, only with the explicit permission of the publisher.

© 2024 All rights reserved

Introduction

With the Alphavan, you have opted for a very high-quality motorhome with many amenities. So that you have a lot of fun with this vehicle, you will receive hints and useful recommendations in this operating manual, which should support you in the use of the Alphavan and the many innovative systems. This instruction manual is mainly dedicated to the Alphavan-specific upfitting behind the B-pillar of the Alphavans.

At the same time, you are welcome to contact us at any time:

Email: kontakt@alphavan.de

We wish you a lot of joy with the Alphavan and above all exciting and unforgettable moments on the road.

Your Alphavan Team

P.S.: Our vehicles are constantly being further developed. We ask for your understanding that changes in form, equipment and technology are possible.

General

Use the vehicle only in technically perfect condition and have faults that affect the safety of people, or the vehicle rectified immediately by specialist personnel.

The braking system of the vehicle may only be tested and repaired by approved and qualified personnel.

The vehicle is intended exclusively for the transport of persons. Please carry baggage and accessories only up to the technically permissible maximum mass.

Vehicle dimensions

Please note the dimensions of the vehicle at all times – especially when passing under bridges or underpasses.



In the case of underpasses, tunnels or similar, please note the total height of the vehicle (including roof loads). The route guidance of the navigation system

does not take into account the height and the permissible total weight of the Alphavan – so you cannot rely on the guidance of the navigation system even when the route guidance is active.

Environmental Information

The Alphavan team is keen not to compromise the peace and cleanliness of nature. Therefore, we would like to provide the following information:

Wastewater of all kinds and household waste do not belong in the street gully or in the wild. Wastewater should only be collected in the wastewater tank or, if necessary, in other suitable containers.

The wastewater tank and the toilet cassette may only be emptied at specially designated disposal stations on campsites or parking lots. When staying in cities and municipalities, the instructions on the parking lots must be observed.

We recommend emptying the wastewater tank as often as possible, even in the event that the wastewater tank is not completely filled (hygiene).

Please never let the toilet cassette get too full.

Please do not let the vehicle engine run unnecessarily when stationary. The operating temperature of the engine is reached most quickly by driving.

Country-specific regulations in the context of cargo on the rear, tolls and other traffic safety requirements

In this section, we would like to provide some information about country-specific regulations for tolls and other traffic obligations. This compilation is explicitly not intended as a complete compendium and in no way replaces the examination of the local legislation in the countries in which you drive the vehicle. Much of the information is also based on direct customer feedback and therefore cannot be seen as proven.

Germany:

- If loads are mounted at the rear of the vehicle (e.g. on a special rear carrier), the following requirements must be observed
 - o The load must not protrude more than 150cm to the rear (reference point is the rear light)

- If a load protrudes >100 cm to the rear (e.g. when mounting bicycles), a 30 x 30 cm flag, a light red sign of the same size or a red cylindrical body with a diameter of at least 35 cm must be attached to the protruding load. However, this marking must not be higher than 1.5 m above the roadway.
- The loads must not cover the beam angles of the rear lights. If the loads cover the rear lights, suitable repeat lighting / additional lighting must be installed.

Austria:

- In the period from 1 November to 15 April, all trucks with a maximum permissible gross vehicle weight of more than 3.5t and buses as well as vehicles derived from such vehicles (such as the Alphavan as a 4x4 version with 4.1 t GVW) must carry suitable snow chains for at least two wheels. When carrying appropriate snow chains, please make sure that their test certificate is also accepted in Austria.
- Motorhomes with a gross vehicle weight of more than 3.5 tons (such as the Alphavan as a 4x4 version with 4.1t GVW) need a Go-Box on expressways and motorways in Austria. This is a box about the size of a cigarette box that communicates with the toll portals via radio signal. Whenever you pass one of these, credit is automatically debited from the box. The successful debit is confirmed with a beep. Meanwhile, there are various providers (such as ADAC or maut1), which also offer such a unit for other countries (such as Switzerland, Spain, France, Italy)

Switzerland:

- Vehicles over 3.5t GVW must pay a heavy vehicle charge (PSVA) on all roads. It is levied for driving on all roads (not only motorways and motorway-like roads with white-green signage) and staying, even if the vehicle is not moved, e.g. on a campsite. Payment of the PSVA is possible before entry via app "Via" or at the border crossings. The amount of the heavy vehicle charge depends on the total weight and length of stay.

- Vehicles over 3.5 t GVW must carry a 6kg fire extinguisher of the EN 3 standard

France:

- If you are travelling in France with a vehicle, you may need a French environmental badge. Be it because it is prescribed for the respective environmental zone in different metropolitan regions, or because fine dust alarm has been declared. This sticker "Crit'Air" can be requested via the Internet by providing vehicle-specific information.
- All vehicles with a gross vehicle weight of more than 3.5 tons (such as the Alphavan as a 4x4 version with 4.1 t GVW) must have three so-called "angles-morts" signs attached to their vehicle within France. Please note the special regulations for attachment.



Safety

General

Please close all doors, exterior flaps and windows when leaving the vehicle. In addition, please check before driving that all push locks are locked, and the drawers are properly retracted.

Warning /emergency triangle and first aid kit according to DIN 13164 are required by law and must be always carried in the vehicle. At the time of delivery, the warning triangle and the first aid kit are located in the lower storage compartment in den co-driver door.

Please make sure that the vehicle is only moved in road traffic if the driver has a valid driving licence for the vehicle category.

In the event of a possible resale of the vehicle, please hand over all operating instructions for the vehicle and the built-in appliances to the new owner. The operating instructions of the systems of different manufacturers must be observed by the user of the vehicle.

Please close all doors, drawers, and flaps in the interior at the beginning of the journey. Also, hangout the table at the beginning of the journey and store it safely. In addition, please close all windows, roof hoods and outer flaps and close the flap locks, if available.

On the first ride and after a wheel change, please make sure that the wheel bolts/wheel nuts are pulled firmly after 50 km – in the following time regularly check for a firm fit.

Tires, suspension, and steering are subjected to additional stress when snow chains are mounted. Drive slowly with snow chains (maximum 50 km/h) and only on roads that are completely covered with snow. The vehicle may otherwise be damaged.

Please never leave children alone in the vehicle.

Keep materials away from heaters and cooking appliances and do not use or install portable heaters or cookers for fire safety reasons.

Tire pressure

At this point, a general overview of the recommended tire pressure for different wheel variants and models is presented. Please identify the type that is valid for you.

Recommendation Alphavan with rear-wheel drive:

1. Wheels 16" steel rim (original Mercedes-Benz) with winter/all-season tires

	kPa	bar	psi	kPa	bar	psi	kPa	bar	psi	kPa	bar	psi
235/65 R 16 C 121/119 R	300	3,0	44	300	3,0	44	350	3,5	51	450	4,5	65

2. Wheels 17" aluminium rim (original Mercedes-Benz) with summer tires

	kPa	bar	psi	kPa	bar	psi	kPa	bar	psi	kPa	bar	psi
235/60 R 17 C 117/115 S	310	3,1	45	310	3,1	45	380	3,8	55	460	4,6	67

3. Wheels 18" ORC (spoke design) with Conti Van Camper tires

Luftdruck

X250 bis 4500kg

mit 255/55 R18CP 120R

	Vorderachse	Hinterachse
Leer	3,2 bar	3,8 bar
Beladen	3,8 bar	4,8 bar

Maximaler Luftdruck:
6,0 bar bei 2800kg Achslast

Drehmoment für die Radschrauben:
160Nm

ORC Exklusiv GmbH

Tel.: 49-(0) 7335-92 33 050 | www.orc-exklusiv.de

Recommendation Alphavan with all-wheel drive 4x4:

1. Wheels 16" steel rim with (Original Mercedes-Benz) winter tires 4x4

	kPa	bar	psi	kPa	bar	psi	kPa	bar	psi	kPa	bar	psi
225/75 R 16 C 121/120 R	320	3,2	46	320	3,2	46	370	3,7	54	490	4,9	71

2. Wheels 18" ORC (spoke design) with General Grabber AT³ tires 4x4

Luftdruck

Mercedes-Benz Sprinter

mit 265/60 R18 119S

Achslast in kg	Luftdruck in bar
1600 kg	2,5
1800 kg	3,0
2090 kg	3,5
2200 kg	3,75
2350 kg	4,0
2600 kg	4,5

Maximaler Luftdruck:

4,5 bar bei 2600 kg Achslast

Drehmoment für die Radschrauben: 160Nm

ORC Exklusiv GmbH

Tel.: 49-(0) 7335-92 33 050 www.orc-exklusiv.de

Snow chains

Before you start your journey, please check whether you need to carry snow chains and which snow chains are suitable for your vehicle. Especially when using special wheels with special tires, it is important to check in advance which snow chains really fit the vehicle body.

For example, it is not possible to install snow chains on the front wheels with 18-inch wheels and General Grabber AT3 tires. In this scenario, however, snow chains could be fitted to the rear wheels. One possible type of snow chain is the Veriga Arktik A-22-5.5 model for the wheel/tire dimension 265-60-R18.

Warning triangle and first-aid kit

When the Alphavan is delivered, you will find the warning triangle and a first-aid kit in the lower storage compartment of the passenger door.

Electrical Installation

Electrical installations may only be inspected or repaired by qualified personnel.

The manufacturer's operating instructions enclosed with the vehicle at the time of handover are authoritative and must be observed by the vehicle user. This includes, in particular, the operating instructions for electrical systems, e.g. the charger, which provide specific information on the maintenance of electrical systems.

Before carrying out work on an electrical system, make sure that all devices are switched off, that the battery is clamped off and that the vehicle is disconnected from the mains power supply.

Only original fuses with the specified values may be used. Please only replace defective fuses if the cause of the error is known and eliminated. In particular, fuses must never be bridged or repaired.

Because electrical cables and contacts can come loose due to vehicle movements and vibrations in a motorhome, all electrical wires must be checked regularly to ensure that they are properly seated.

Payload and Weight

Make sure that the payload in the vehicle is evenly distributed at the beginning of the journey. When loading the vehicle, observe the technically permissible maximum mass and the permissible axle loads (see vehicle documentation). Overloading the vehicle and incorrect tire pressure can cause the tires to burst and the vehicle may get out of control. Only the technically permissible maximum laden mass and the mass in running order are indicated in the vehicle documents and not the actual weight of the vehicle.

Please also note that the mass of the vehicle in running order is indicated with a filling quantity of 20l in the freshwater tank and only 90% level for fuel. A full 90l freshwater tank has significantly more weight. The freshwater tank can be drained to the 20l level at any time via the built-in drain valve.

In addition, we recommend that you always look for alternatives for all equipment and items in your Alphavan that are lightweight to keep the overall weight of your everyday items low. For example, when using plastic dishes and very light pans, pots, and cutlery, you can significantly save weight.

In addition, please note that the weights stated in the vehicle documents may have tolerances that must be observed.

We recommend that you undergo the vehicle to a test weighing in a regular loading situation for you, so that you get a feeling for the actual weight including passengers.

Please adjust the speed of the vehicle to the payload because a high payload extends the braking distance.

Likewise, uneven, or one-sided loading changes the driving behavior.

If the technically permissible maximum laden mass of the vehicle is more than 4 tonnes, small ramps shall be used when parking on inclines or descents. The ramps are included as standard accessories for vehicles with a total mass of more than 4t.

Accessories and Tires/Rims

When accessories or optional extras are added, the dimensions, weight and handling of the vehicle may change. Some of the accessories must be entered in the vehicle documents.

Please use only rims and tires that are approved for the vehicle.

Road Safety

Please check the function of the signalling and lighting devices, the steering system, and the brakes at the start of the journey. After a longer standstill period (approx. 7 months) it is recommended to have the brake system checked by an authorized specialist workshop.

Please check from the start of the journey that the slide-out step on the sliding door and the awning is completely retracted.

While driving, all rotating seats must be in the direction of travel and must be locked and remain there the whole time.

Before starting the journey, move the flat screen and the screen mount to the basic position and secure them.

Before starting the journey, remove the loose cover of the sink in the kitchenette and store it safely in the kitchen block or in the wardrobe.

During the journey, people are only allowed to stay in the permitted seats. The permitted number of seats can be found in the vehicle documents.

Passengers are required to wear seat belts. Buckle up before driving and stay buckled up while driving.

Please do not buckle up items together with people. Seat belts are not sufficient for people with a height of less than 150 cm. In this case, additionally use restraint devices and check their test certificate.

Please replace seat belts after an accident.

Children must always be secured with the child safety devices prescribed for their height and weight.

Please note the total height of the vehicle (including roof loads) for underpasses, tunnels, or the like. The route guidance of the navigation system does not consider the height and the permissible total weight of the Alphavan.

The vehicle offers a large attack surface for wind. There is a particular danger in the event of a sudden crosswind – the standard Crosswind Assist from Mercedes-Benz reduces the effects that occur, but caution is generally required.

In the interest of your safety, adjust the driving speed to the respective traffic situation and surrounding situation. The national speed limit legislation must be adhered to.

Caution should be exercised when coupling or uncoupling a trailer hitch. There is a risk of accident and injury. The maximum load and rear axle load of the towing vehicle must be observed and must not be exceeded. The values of the support load and the rear axle load can be found in the vehicle documents and the trailer papers.

After coupling, please check the lighting system of the trailer.

AdBlue

Like all modern Diesel vehicles, the Alphavan is also equipped with an AdBlue system.

Please note that AdBlue freezes at a temperature of about -11°C. However, all Mercedes-Benz motorhomes are equipped ex works with an AdBlue preheating system, so that appropriate winter operation is guaranteed. However, when refilling or starting the vehicle at temperatures below <-11°C, the level cannot always be displayed correctly. By driving for about 20 minutes, the level should also be displayed correctly in the instrument cluster.

The refilling of AdBlue can be done via the corresponding filling nozzle under the vehicle hood. The current level can be viewed via a special "Service" menu in the instrument cluster. In addition, various warnings are issued if the AdBlue level is too low. The capacity of the AdBlue tank is about 18 liters.



Basic Motorhome Functions

In this section, we would like to give you an overview of the most important basic functions of the Alphavan, which are not explained separately in one of the chapters below.

For the built-in appliances (heating, stove, refrigerator, etc.) as well as for the base vehicle (engine, brakes, etc.), the respective operating instructions and operating instructions are decisive.

Keys

With your vehicle you will receive all the keys necessary for the vehicle.

Two keys each:

- for the vehicle itself
- for the drinking water filler neck
- for the service flap for removing the toilet cassette

Please leave spare keys at absolutely secured and safe locations outside the vehicle.

Admission

Your motorhome is a motor vehicle subject to registration. For admission you need the following documents:

- the vehicle registration document
- an insurance confirmation (EVB number)
- your identity card
- potentially a specific authorisation
- an application for admission

Landline Power

The Alphavan can be externally powered via the outdoor landline connection on the driver's side in the rear area, which is located under the flap marked with a power sign. A corresponding adapter cable from the 230V Schuko plug known in the household to the landline power plug on the Alphavan is enclosed with the vehicle on delivery in the FlexPort compartment at the rear left. Additional adapters for special plugs can be purchased from retailers.



Note: Please make sure that the landline power plug is no longer connected when moving the vehicle.

Important Note: The vehicle should be supplied with landline power during a longer standstill period lasting >3-4 days. In this case, please also switch the voltage converter into the "0"/Off" position so that it cannot remain activated in the event of sudden power loss and thus discharges the auxiliary battery. Also make sure that the MBAC display is not set to continuous operation.

The circuit for the landline power supply is monitored with a residual current circuit breaker ("RCD switch") just like the internal 230V fuses. If there are current peaks in the external circuit, this switch triggers and deactivates the external 230V interface. If this switch triggers while the voltage converter is not in the 0/"OFF" position, the voltage converter will remain active and will discharge / drain the battery. This is to be avoided!

The circuit breaker is in the trunk in the FlexPort at the front on the passenger side. If the power supply via landline power is not working, please check whether the circuit breaker is really in the active position ("moved to top").

Note: In our own tests with the Alphavan, it has been shown again and again in certain regions that sometimes the landline power has worked quite unreliably and that it has sometimes even helped to change the landline power connection at the parking space.

Important note: Please switch the voltage converter into the "0"/Off" position for longer standstill periods >3-4 days in order not to discharge the battery. Also make sure that the MBAC display is not set to continuous operation.

Alphavan auxiliary / living battery (LiFePO₄, 210Ah) and maintaining battery performance and service life through regular charging

The Alphavan is equipped with a battery of Super B. The "Nomia 12V210Ah" is a rechargeable lithium phosphate battery (LiFePO₄) with a nominal capacity of 210 Ah.

Capacity is the amount of electricity that a battery can store.

The capacity of a battery is expressed in ampere-hours (Ah). If the battery has a capacity of 210 Ah, then the battery can emit a current of 1 A for 210 hours or 2 A for 105 hours.

If the vehicle is not connected to the 230 V supply or if the 230 V supply is switched off, the auxiliary battery supplies the campervan part with electricity. auxiliary battery has only a limited energy supply.

When the vehicle engine is running, the auxiliary battery and the starter battery are recharged by the vehicle alternator.

At low outside temperatures, the battery loses capacity. An older battery no longer has full capacity. The more electrical consumers are switched on, the faster the energy supply of the living room battery is consumed.

Important Note: The battery can provide energy to the consumers until temperatures significantly below 0°C. Though, the battery can only be charged if it has a temperature above 0°C. If you want to charge the battery during very cold temperatures, you need to accordingly heat up the interior of the Alphavan first.

Important note: For longer standstill periods (3-4 days and longer), the vehicle must be supplied with landline power in order to enable the auxiliary battery to be optimally charged.

Important note: Please switch the voltage converter to the "0"/Off position for longer periods >3-4 days in order not to discharge the battery. Also make sure that the MBAC display is not set to "continuous operation" under "Settings".

Note: Even the auxiliary battery is a high-quality Li-ion battery, whose energy is almost completely available, there are also various peculiarities to consider here:

Please avoid charging levels below 10% by regularly recharging or switching off consumers.

Note: Please note that in particular the installed voltage converter in the Alphavan consumes energy when switched on, even if no other consumers are active. Therefore, please always deactivate the voltage converter before parking the vehicle for a longer period of time (see chapter on voltage converter).

If the state of charge falls below a critical value, it may happen in individual cases that the battery management system completely deactivates the battery in order to protect the battery from permanent damage. In this case, the battery must be reactivated and recharged within the following days to prevent battery damage. This can only be reactivated via a manual service function in a workshop.

If you have the feeling that the battery does not charge despite external shore power supply, please check the following points:

1. Is the main 230V fuse under the flap of the front cabinet in the FlexPort or has it been "triggered" by external current peaks?
2. Can the rear display of the MBAC be operated?
3. If the rear display of the MBAC can be operated and is active: when plugging in landline power, is a charging symbol displayed in the status bar and "Charging cable plugged" is displayed in the battery menu?
4. Does the display of the voltage converter (next to the display of the MBAC) show special messages?
5. Have you already tried to use a different landline power connection for charging?
6. Is the temperature in the vehicle (around the battery) significantly above 0°C?
7. If the state of charge of the battery shows 0%: please deactivate both 230V protection switches and set the voltage converter to "OFF" (middle position of the switch on the front side of the voltage converter). Charge the vehicle via landline power with the voltage converter switched off.



The battery is located in the FlexPort on the passenger side in the middle of the cabinet. It is covered with a grey panel secured by four plastic buttons. To get directly to the battery, these buttons have to be loosened and the panel is to be pushed away / lifted forward (see pictures below).

Important Note: Electrical installations may only be inspected or repaired by qualified personnel. Especially work on the high-capacity batteries is only to be done by qualified personnel.

Important Note: No changes or repair works on the 230V electrical circuits it to be made by non-qualified personnel – danger of death and severe injuries!

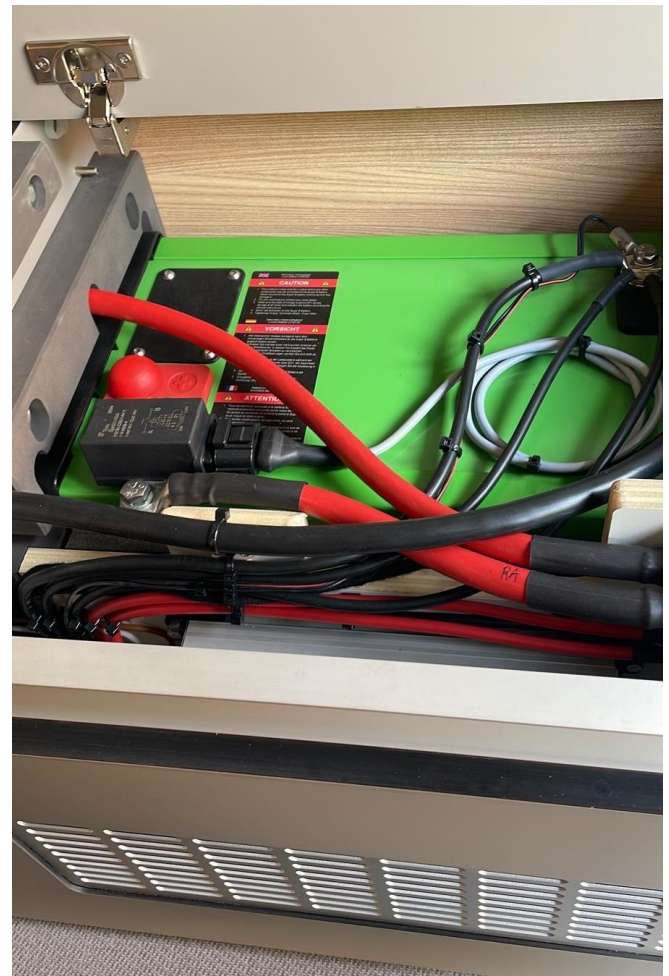

A battery is a chemical energy storage device that must be used carefully to maintain battery performance and lifetime. Otherwise, there is a risk that the battery will suffer permanent damage.

In particular, charging states with a very low state of charge are critical. Even though SuperB's battery has its own battery management system that monitors the state of charge and completely deactivates the battery in critical states, this function cannot prevent damage if the battery is used improperly.

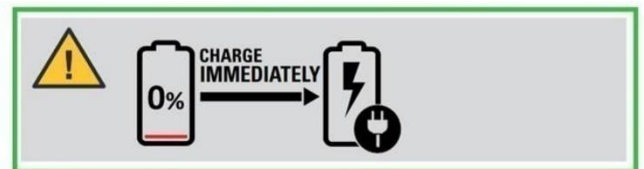

Important note: Please always avoid charging states of the battery that are less than 10% of the total battery capacity (see displaying the MBAC). If the charging state is below 10%, please supply the vehicle (and thus the auxiliary battery) with landline power immediately

or start the vehicle's engine so that the auxiliary battery can be charged.

Important note: When parking the vehicle for longer periods of time (two weeks and longer), the battery must first be fully charged and then the vehicle must be supplied with landline power so that the state of charge of the battery does not fall below a critical level and cause permanent damage.

Important note: Permanent battery damage due to complete discharge cannot be declared as a warranty. Please ensure proper storage and charging of the auxiliary battery at all times.

Alphavan furniture (Vunder Tech) and surfaces / décor

All furniture in the Alphavan and the (if available) removable camping table are produced with the lightweight construction process "Vunder Tech". This innovative production process ensures that the complete furniture set is very light and thus the payload of the vehicle is optimized.

Each piece of furniture is constructed in a special sandwich construction. On the outside, two high-quality HPL decors in the thickness of 0.9mm are installed. In the core there is an approx. 14mm thick EPS layer (compressed polystyrene), which has a much lower density compared to conventional materials such as wood and thus ensures the light weight.



All edges are encapsulated with polyurethane (PU) plastic and are therefore waterproof. In addition, PU blocks / inlets have been integrated in all places where screwing must be done or where the furniture part requires special requirements for stability.

The outer HPL layers are made of high-quality materials, as they are also used in kitchens and therefore offer similar properties in the context of resistance to external influences. At this point, however, it should be explicitly pointed out once again that this resistance is not protected against extreme external influences such as extreme heat or extreme pressure.

In particular, the principle applies never to place a hot pot, for example, on the work surface in the kitchen or

on the table. As usual in a normal kitchen, appropriate protective coasters made of various materials should also be used here. Depending on temperature and contact time, irreparable damage may otherwise occur.

Important note: due to the sandwich structure of the furniture parts, it is also not possible with the Alphavan furniture set to insert new drilling points or screwed attachments directly into the fronts / decors of the furniture. As a result, the corresponding furniture parts would be irreparably damaged. To install additional attachments in the Alphavan interior, it is advisable to rely on special adhesive solutions that can be removed afterwards without leaving any residue.

Interior Floor

The overall concept of the Alphavan is realized in lightweight construction. The same applies to the sandwich structure of the floor in the Alphavan. This floor is also characterized by a reduced weight.

In order not to damage the sandwich structure of the floor, we recommend protecting the floor from moisture and always protecting it from sharp objects such as pebbles or pointed high heels.

Shoes with pointed heels or small pointed stones can leave permanent pressure points in the floor covering. Therefore, we recommend not to wear shoes with pointed heels in the vehicle and to remove small stones immediately.

Applied rubber mats or prolonged exposure e.g., of ketchup, carrot juice, ballpoint pen ink, blood or lipstick can lead to discoloration of the floor covering. Always remove stains on the floor immediately.

(Swiveling) Seats and Ladder

The Alphavan is equipped with rotating driver and front passenger seats. The rotation of the seats should be tested out several times in order to get a feeling for the swiveling area. In particular, it must be checked that the seats do not collide with the B-pillar, with the central cup holders or with the steering wheel during rotation.

Please make sure that you rotate the seats from the outside of the vehicle with the doors open.

To rotate it, please move the corresponding seat forward so that the backrest cannot collide with the B-pillar during a rotational movement.

For longitudinal adjustment of the seats, you will find a corresponding lever at the bottom of the front of the seats on the side of the belt buckle.

Then please unlock the swivel mechanism on the small lever in the middle of the lower front of the seats and turn the respective seat with the backrest in the direction of the B-pillar (driver's seat: clockwise, passenger seat: counterclockwise).



Each Alphavan comes with an ascent ladder to climb the fixed bed above the FlexPort. Hang the ladder with the two brackets in the support bar on the bed cover and check for a secure hold before use.

As you climb forward up the ladder into the bed, we recommend the safe descent backwards from top to bottom.

Windows and Ventilation

The Alphavan is equipped with a total of five high-quality side windows (two in the living area, one in the bathroom and two in the sleeping area) and two roof windows (one in the living area, one in the sleeping area). If you have selected the options of two additional windows in the FlexPort, these two windows feature that same functions as the other ones. In addition to very good insulation, the windows are also characterized by first-class functions.

A fly net can be stretched on all windows by pulling a slider from bottom to top. A foldable darkening curtain of the window can be achieved via the slider in the

opposite direction. To pull on, please grab the slider in the middle of the handlebar, pull it from bottom to top and release it at the desired height. The darkening or insect protection then remains at this height.

Note: To avoid disturbing noises while driving, we generally recommend completed extending the fly net – if it is completely extended, it snaps into place via a magnetic closure and is fixed firmly.

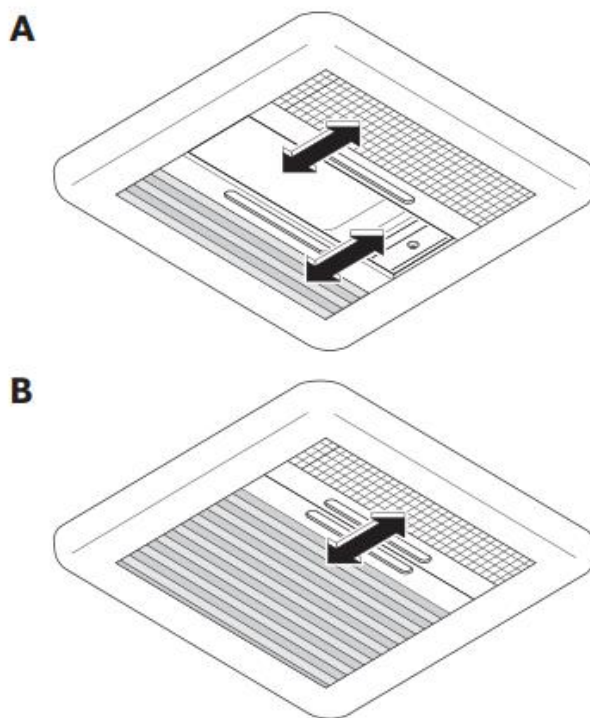

The roof windows can be placed in several positions.

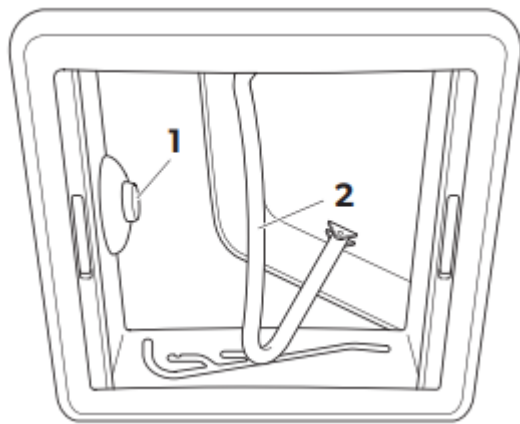
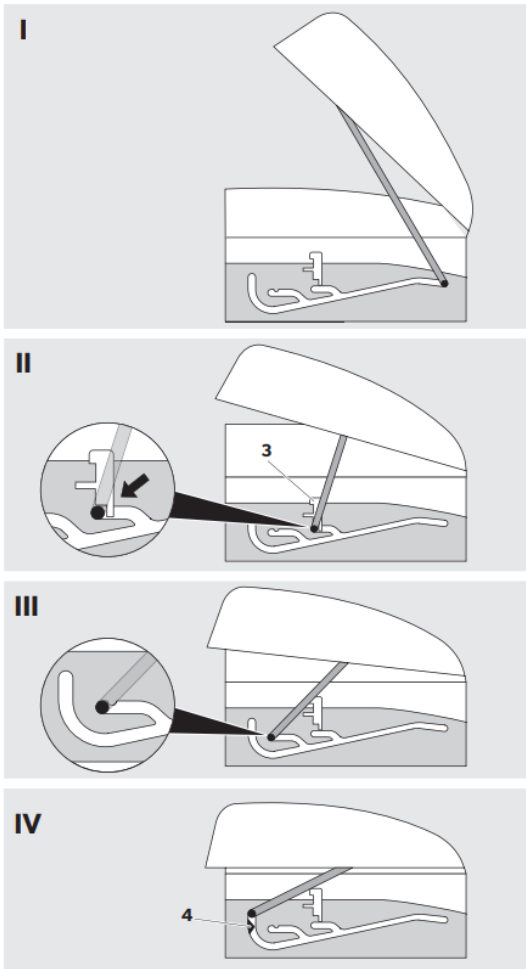

Opening the Roof Window: Press the safety button (1) and pull the bracket (2) down with both hands. Pull the bracket in the rails to the rearmost position.

Closing the Roof Window: Push the bracket (2) slightly upwards with both hands. Slide the bracket back in the rails. Push the bracket upwards with both hands until the bracket is above the safety button (1).

We recommend frequent and targeted ventilation as this ensures constant air exchange. This prevents condensation in cool weather conditions. If heating

power, air distribution and ventilation are coordinated, a pleasant living climate can be created in cool seasons.

Note: Please make sure that all windows are closed during the journey.

12V Sockets

Devices with a maximum of 15 A can be connected to the sockets of the 12 V on-board electrical system ("cigarette lighter sockets").

USB Ports

In the living area of the Alphavan, USB charging ports are integrated at various points. A double USB port is available in the storage compartment in the seating area, in the storage compartment in the sleeping area above and in both storage compartments in the FlexPort. All USB ports can only be used to charge USB-compliant devices.

Note: In the TV cabinet there is - next to the 230V socket and above the plug for connecting the sound line of the TV - also a USB port. However, this port is not active – this is not a malfunction.

Overview of Switches in the Alphavan

In the following section we explain the switches assignment:

Panel over entrance area sliding door

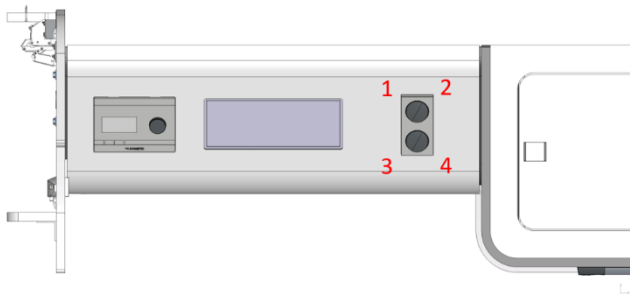

1. Turn seating group lights on/off and dim
2. Turn sleeping area lights on/off and dim
3. Turn on/off display of MBAC
4. Turn awning light on/off and dim

Switches on kitchenette in the entrance area sliding door

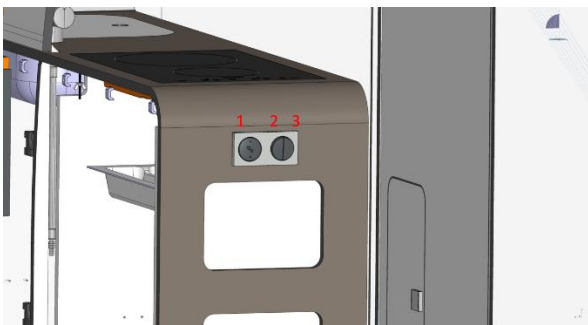

1. Extract and retract steppers
2. Turn off all lights (e.g., when leaving the Alphavan)
3. Turn on/off and dim spots in the living area

Switches on rear wall kitchen

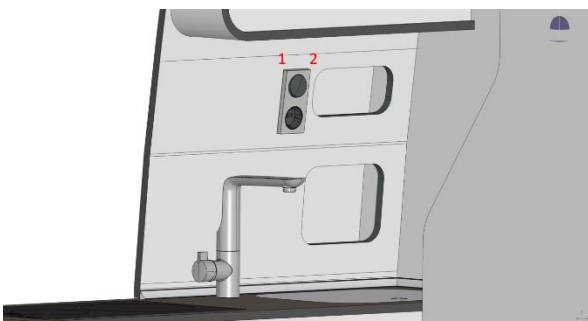

1. Turn kitchen lights on/off and dim
2. Ambient lighting switch on/off

Switches on side of refrigerator

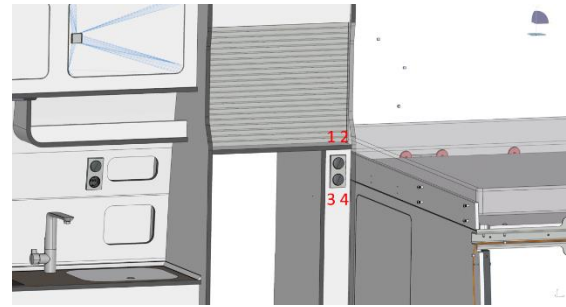

1. Turn on/off bathroom lighting
2. Spots To switch the living area on/off and dim
3. Ambient lighting on/off
4. Turn FlexPort light on/off

Switches in the FlexPort at the storage compartments

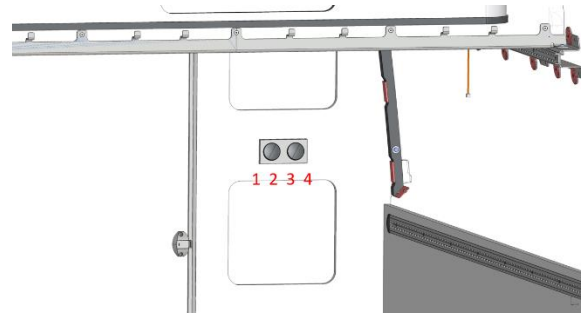

1. Switch the living area lighting on/off and dim
2. Turn FlexPort main light on/off and dim
3. Turn FlexPort ambient lighting on/off
4. Ambient lighting living area on/off

Switches in the FlexPort rear and rear doors

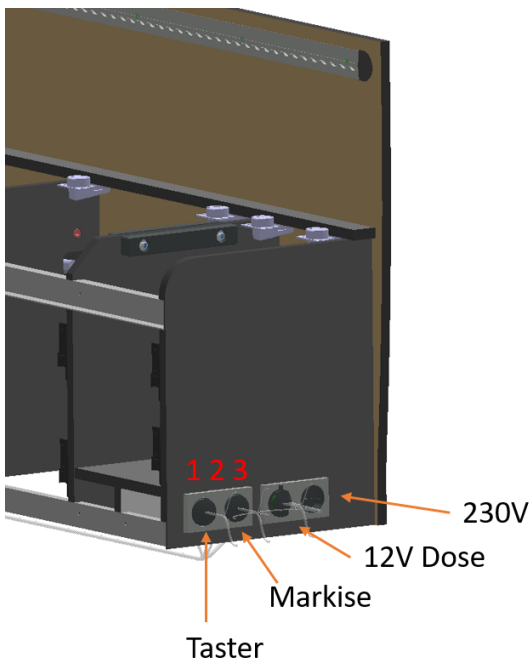

1. Turn main light FlexPort on/off and dim
2. Turn FlexPort ambient lights on/off
3. Extract and retract awning

Switches sleeping area

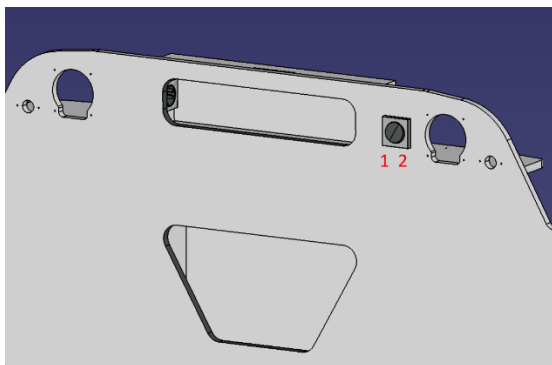

1. Spots sleeping area on/off and dimming
2. Ambient lighting on/off

Slide-Out Step

Please make sure that when extracting or retracting the slide out step, no person or object is standing in the direct swivel area while it retracts or extends. Please do not step on the slide-out step until it is fully extended.

Please be aware that the step has an automatic mode, which can be activated via the MBAC. If this mode is active, the step will run automatically when the sliding

door is opened – even in these cases, please pay attention to a free swiveling area.

Please always completely extract the step before entering.

The switch for operating the step is mounted inside the vehicle in the area of the sliding door.

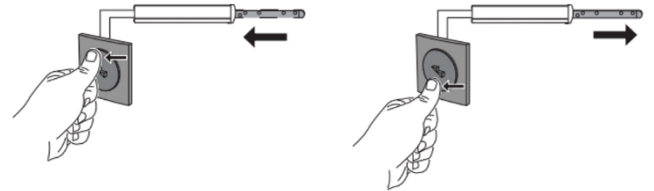

Extend: Press down the switch.

Retract: Press the switch upwards.

Note: When using the physical switch or the touch keys on a touch screen to move the slide-out step, only very short presses might not trigger the movement of the steps. You might have to hold the according switch for a little longer period of time to trigger the slide-out step movement.

Important note: Please note that the step must be retracted while driving. Even if the MBAC has a corresponding check function, it is your responsibility to check before each ride that the step is completely retracted. Especially when the instrument cluster shows a message “Step Extracted” please make sure to retract the step.

Important note: If the premium step is installed in your Alphavan, which folds completely under the vehicle when retracted, there is a special feature: If the 12V power supply of the mounting systems (e.g. via the red 12V on/off switch) is interrupted while the step is extracted, it is likely that the physical buttons and the softkeys in the MBAC UI must be activated in reverse order and that the MBAC UI has a detected extracted status even though the step is retracted. In this case, please interrupt the 12V supply again when the step is retracted.

Important note: If the premium step is installed in your Alphavan, which folds completely under the vehicle when retracted, there is a special feature: in the driver's seat compartment there is a manual button for the step, via which the step can be retracted separately.

Insect repellent / Fly screen sliding door

Please insert the insect screen completely before closing the sliding door, otherwise it will be damaged.

Please note that the insect screen is provided with mounting clips at the vehicle delivery. These must first be removed before the insect screen can be put on. To avoid noise while driving, however, it is advisable to clip these clips back on while driving.

Note: In certain cases the opening and closing of the insect repellent screen moves a little ponderous. In general it helps to move the insect screen with two hands placed on the middle of the plastic fly screen edge. To smoothen the movement of the fly screen, tilting the plastic edge a little towards the vehicle interior helps.

MBAC – Mercedes-Benz Advanced Control

The MBAC is the central control unit from Mercedes-Benz, which allows the control and visualization of different motorhome systems.

The MBAC basic display provides an overview of all relevant systems.



Important note: Together with our partners at Mercedes-Benz, we are in the ongoing development of the MBAC and would like to continue working on enabling new functions via this Smart Home Panel. However, this can lead to a new software of the MBAC visualizing functions that were not yet available from the components in the Alphavan that were installed when the vehicle was sold. This is not a malfunction but due to the progress of controllable functions. For example, it may happen that a refrigerator is installed in the Alphavan that does not yet support the control protocol available in the MBAC. In this case, the

refrigerator must be controlled via its own control panel and cannot be controlled via the MBAC, although a corresponding menu is available.

The following functions can be visualized or controlled via the MBAC:

- **Lights: All light groups can** be switched on and off and dimmed via the MBAC in the "Light" menu. All lights except for the light in the storage compartment or outside the driver's seat can also be operated separately via light switches in the interior. If the light switches are held down for a longer period of time, the corresponding lights are dimmed automatically.

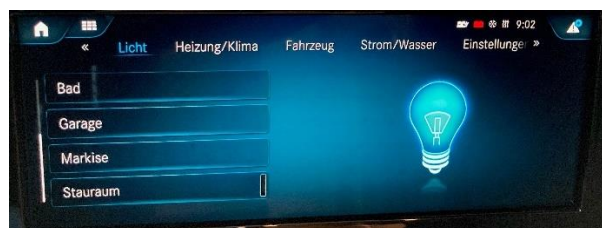
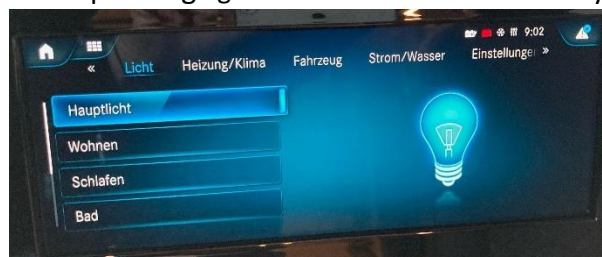

- **Heating/hot water:** the heating can be switched on and off via the menu "Heating/Air Conditioning" → "Heating". In addition, the temperature can be set, and a time control can be configured. In addition, in the "Heating/Air Conditioning" menu "Heating Settings", heating can be explicitly selected via landline

power or Diesel fuel. In "automatic" mode, a mixed heating mode with electric current and Diesel auxiliary heating is used. In addition, in the menu "Heating/Air Conditioning" → "Hot Water" the hot water supply can be activated, and the corresponding temperature (40°C or 60°C) can be set.



- **Air conditioning:** The air conditioning can be switched on and off via the menu "Heating/Air Conditioning" → "Air conditioning" and the temperature can be adjusted. In addition, it is possible to switch between air conditioning and recirculation mode.



- **Refrigerator:** The current mode of the refrigerator is displayed in the basic menu and can be adjusted via the specific refrigerator menu "Vehicle" → "Refrigerator". In addition to the basic switching on and off, the refrigerator mode can also be selected there:

- o **Performance:** This is the basic mode, and all cooling levels 1-5 can be selected in this mode.
- o **Silent:** In this mode, the noise of the refrigerator is minimized and thus this mode is particularly suitable during the night. Only levels 1-3 are available in this mode.
- o **Boost:** this mode is suitable for fast cooling of the refrigerator and works only in level 5



- **Awning:** The awning can be retracted and extended via the MBAC display in the "Vehicle" → "Awning" menu. To stop the retracting or extension process, please press the corresponding softkey again. In addition to operating the awning via the MBAC user interface, there is a switch in the rear area of the FlexPort for retracting and extending the awning.

For safety reasons, the awning function uses different vehicle data points (e.g. vehicle speed, engine status or ignition status) to verify whether an operation of the awning is currently allowed. As the operation will be de-activated when the ignition is turned on this needs to be checked constantly. The vehicle shuts down the vehicle bus systems in regular intervals in order to save energy.

During this "sleep period" the MBAC cannot access the necessary information elements on the bus system. At this point, the softkeys for operation of the awning will be deactivated. In order to activate them again, the bus systems need to be woken up. This can be achieved either by opening one of the doors or by shortly pressing the ignition button, for example.

Note: for safety reasons, this function is only available during vehicle standstill.

Note: Please make sure that when extending the awning, the cargo compartment door is not completely open by 270° but by a maximum of 180°, otherwise the awning would collide with the rear revolving door.

Note: If the function to extend the awning on the display is inactive / greyed out, the start button of the vehicle must be pressed briefly (adjust ignition status) to reactivate the function.



user interface, the step can also be retracted and extended via a switch at the entrance area of the kitchenette.

Important note: Before driving, it is essential to make sure that the step is retracted.

Note: If the function to extend the step on the display is inactive / greyed out, the start button of the vehicle must be pressed briefly (adjust ignition status) to reactivate the function.



- **Auxiliary battery:** The state of charge of the 210Ah auxiliary battery can be queried via the menu "Power/Water" → "Additional battery". In addition, it is visualized whether the vehicle is currently being supplied with landline power. As soon as the battery state of charge falls below a certain level, a warning message is listed in the MBAC Message Center.

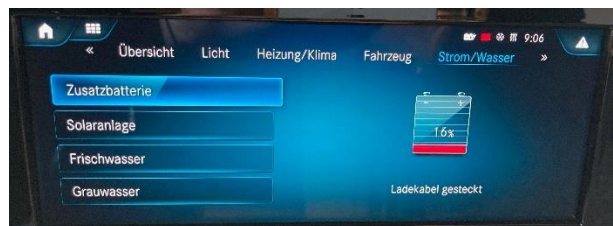

- **Charger:** The built-in charger from Votronic, which ensures that the additional battery is charged either via the vehicle's alternator, via the solar panel or via shore power, has a so-called "silent" mode. If this mode is set, the fan noise of the charger is reduced and is therefore suitable, for example, as a setting during the

night.

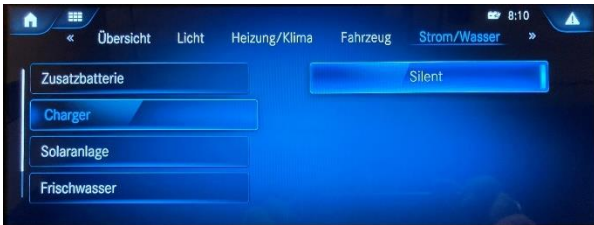

- **Solar system:** The current charging behavior of the solar system installed on the roof is visualized via the menu "Electricity/Water" → "Solar system".



- **Fresh water/water pump:** the level of the 90l freshwater tank is visualized via the menu "Electricity/Water" → "Fresh water". As soon as the level falls below a certain level, a warning is listed in the MBAC Message Center. In addition, the water pump can be activated. Please ensure that the water pump is activated before using the taps in the wet room, outdoor shower, or kitchen. Important note: When not using water, the recommendation is to turn off the water pump in general. Note: If a constant water level close to 0% is detected by the MBAC, the activation of the water pump is prevented.

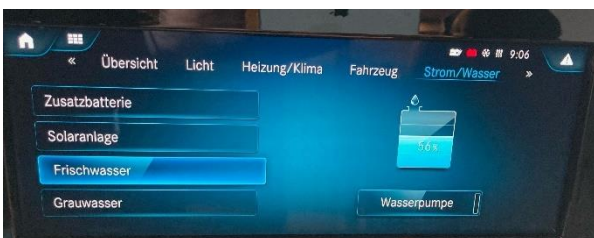

- **Grey water/greywater valve:** the level of the 80l grey water tank is visualized via the menu "Electricity/Water" → "Grey water". As soon as the level exceeds a certain level, a warning is listed in the MBAC Message Center. In addition,

the valve for emptying the grey water tank can be opened and closed. To open the drain valve of the grey water tank, please press, and hold the corresponding softkey on the MBAC user interface. Please note that the electronic drain valve is mounted on the side of the grey water tank and that therefore no complete emptying can be achieved via this valve, but up to a maximum of approx. 15% of the total volume. To achieve a complete emptying, you need to pull the manual red drain valve under the vehicle (driver's side, center). Note: The grey water tank may only be emptied at permitted disposal stations.

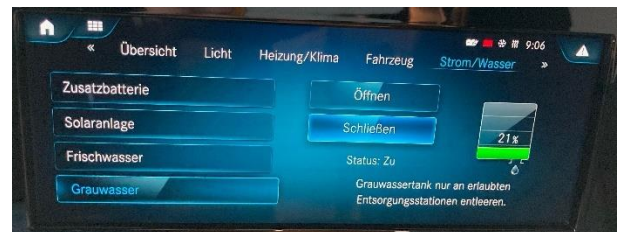

- **Settings:** in the settings the visibility of the MBAC can be activated for Bluetooth pairing and all previously paired Bluetooth devices can be deauthorized. In addition, the display operation in day/night and automatic mode can be selected and the display brightness can be adjusted. In addition, continuous operation can be activated so that the MBAC display remains permanently active – otherwise the display switches off after about 120s of inactivity.

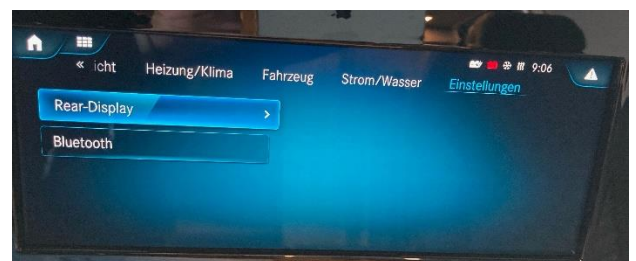

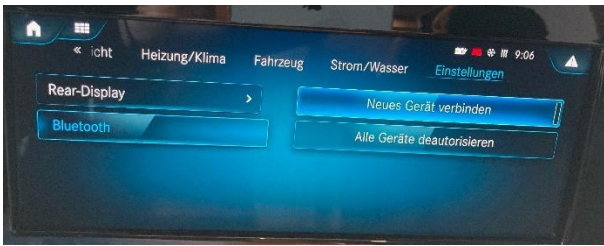

The MBAC can be used and operated in various ways.

The central MBAC touch display is in a panel in the entrance area above the sliding door on the passenger side. If it is switched off (i.e., black display), it can be activated via the button at the bottom of the entrance area.

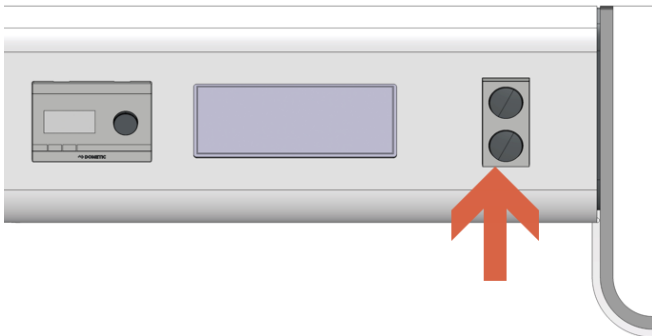

In addition, the MBAC menu is displayed on the front vehicle display MBUX (Mercedes-Benz User Experience). This view can be activated by selecting the "CAMPER" symbol via the touch screen in the Favorites area ("STAR" button on the control bar or by swiping up in the basic menu).



In newer MBUX systems, the function is also integrated directly at the top menu level.





Note: If the MBAC system is in sleep mode after prolonged inactivity, it will take about 10 seconds for it to be operable via the touch display, although all symbols and the user interface are already visible. In addition, it may happen that the touch function in MBAC mode is no longer available in the front display after a longer sleep phase. In this case, the MBAC must be activated again via the rear switch button.

For quick visualization of various status information, certain symbols are displayed on the MBAC display. The warning and status symbols for the fresh and grey water are generally only displayed at standstill and when the engine is off because the filling levels can be falsified by driving movements.





1) Fresh water tank



- a. : Displayed as soon as the level falls below 40%

- b. : Displayed when the level is below 15%. In addition, a message is set in the MBAC Message Center
- c. Note: the red icon and the message will only disappear after filling the freshwater tank over about 30%

2) Grey water tank

- a. : Displayed as soon as the level exceeds 60%
- b. : Displayed when exceeding 85% level. In addition, a message is set in the MBAC Message Center
- c. Note: the red icon and the message will only disappear after draining the greywater tank below about 70%



3) Auxiliary battery

- a. : The auxiliary battery is charged.
- b. : As soon as the state of charge of the auxiliary battery falls below a level of about 25%, this symbol is displayed.

4) Air conditioning

- a. : The air conditioning is active, and the interior is currently air-conditioned.

5) Heating

- a. : The heating is active, and the interior is currently heated.
- b. : The time control of the heating is active, and the heating is activated at the defined times.
- c. : The hot water preparation is active.

MBAC Bluetooth App

The so-called MBAC smartphone app can be used as a further control unit for the MBAC. This app can be downloaded from the Apple App Store for iOS devices or for Android devices from the Google Play

Store. Please note that the Android app may not yet work in the MBAC version.

The app is connected to the MBAC via Bluetooth. For this purpose, Bluetooth pairing must be carried out before first use. Please use the Bluetooth pairing process in the app or in the settings menu. For security reasons, several vehicle-specific entries must then be made in the app. After the Bluetooth connection has been setup, various configuration information is transmitted to the app. This may take a few seconds and will be repeated when the app is restarted. **Note:** not all features of the MBAC may be offered on the smartphone app. In addition, it may happen that certain functions on the app are not 100% optimized, e.g., different icons and various sub-menus (such as settings, etc.).

In the following, the functionalities of the Bluetooth app are described in more detail:



On the start screen, an overview of all available systems is given. If operable, these can then also be operated directly by clicking on the corresponding menu.

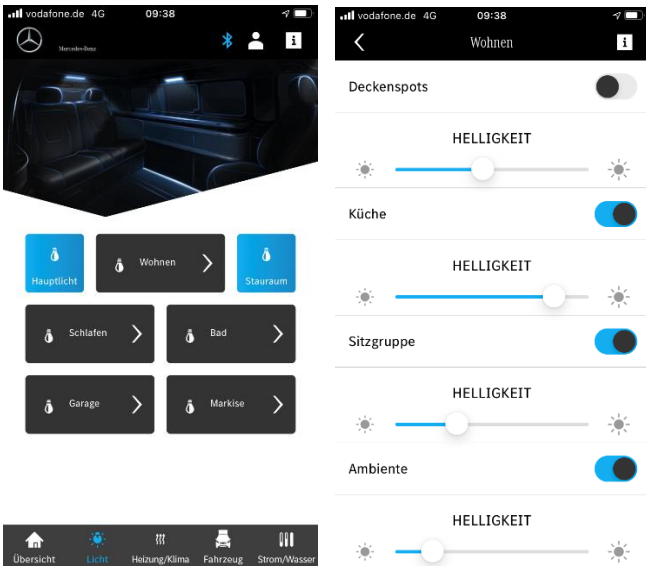

In the light menu, the individual lights can be switched on and off or dimmed accordingly. Activated lights are symbolized by a blue background or by an activated slider.

Various settings and activations can be made in the "Heating/Air Conditioning" menu, as they are also available via the MBAC display.

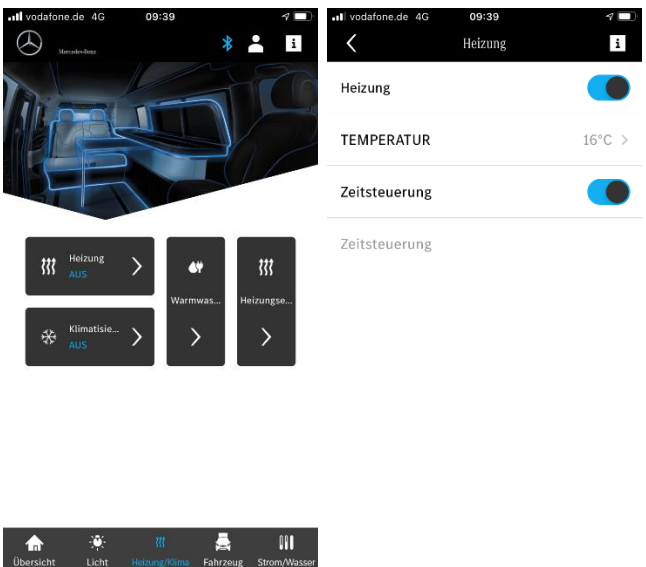

In particular, the time control can also be programmed here.

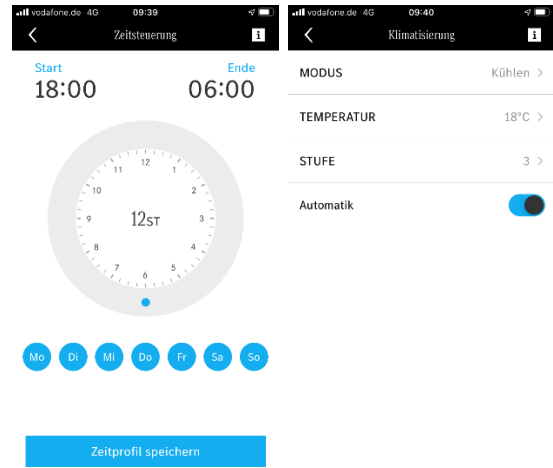

Finally, all refrigerator-specific settings can be made in the "Refrigerator" menu.

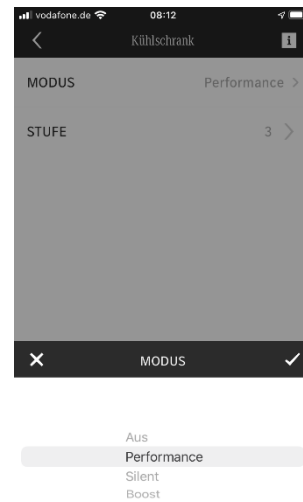

In the menu "Vehicle" the operation of sound system (if installed), step and awning are available.

With the sound system installed you can pair your Bluetooth device as soon as the sound mode "living area" is activated. This mode is deactivated when you start driving.

For the slide-out step, you can activate and deactivate the automatic mode.

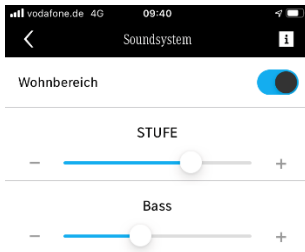

In the menu "Electricity/Water" fill levels are visualized and the water pump can be switched on and off.

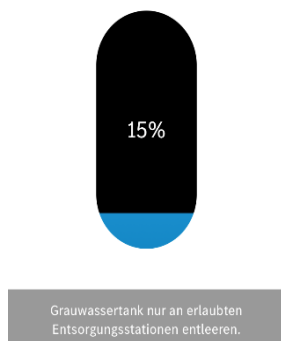
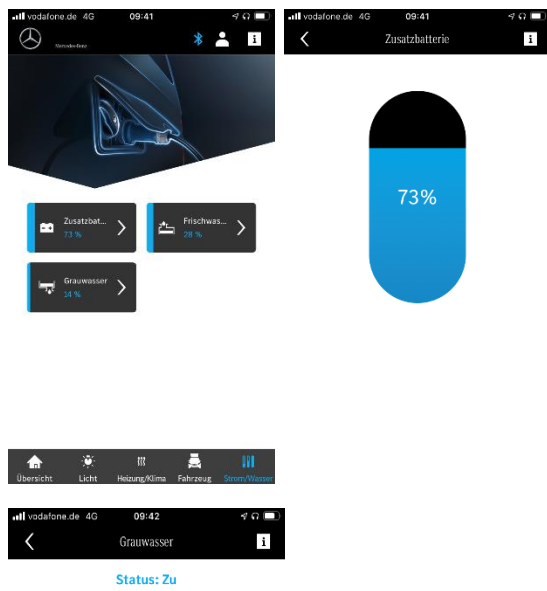

Finally, the so-called "SILENT" mode can be activated in the menu for the charger, in which the background noise during fan operation is reduced.

In the settings menu, various user-specific / Bluetooth settings can be made and warnings / status icons and messages about the MBAC in the vehicle are listed in the submenu "Warnings".

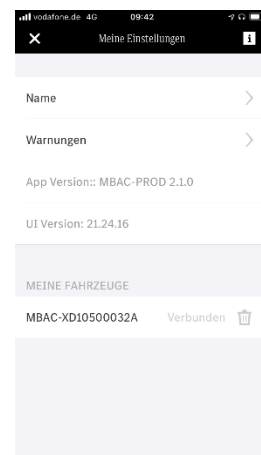

In the subcategory "Solar" the current solar power is displayed.

Freshwater Tank and Drain Valve

The freshwater tank is in the FlexPort in the central trunk space on the driver's side. It has a volume of about 90 liters.

The freshwater tank can be filled from the outside via a lockable tank inlet with a suitable water hose.

To prevent confusion, the fresh water tank is closed with a blue lid.

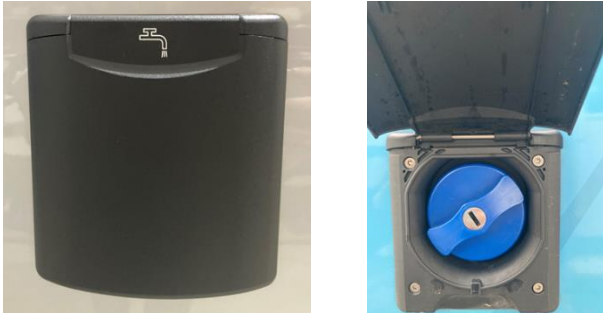

We recommend that you fill the tank up to a maximum of 85% while stationary and never fill it to the brim so as not to burden sealed openings and, in the worst case, to avoid water penetration into the inside of the van. When you fill up the fresh water tank from, it is recommended to check the fill level with the fill level indication window in the FlexPort trunk wall adjacent to the tank. The maximum fill level should be about 2 cm below the visible top edge of this window.

Important note: Please never fill the water tank to the brim under the lid of the access, so that there is water in the inlet pipe to the water tank.

Information on the level of the tank can be obtained via the MBAC or via the viewing window in the trunk in the FlexPort on the driver's side.

Note: When filling the freshwater tank, make sure that the filling hose is inserted into the water tank up to the 90-degree valve, see picture (red arrow). The hose should therefore be entered approx. 50cm into the tank inlet.



Important note: Please do not overturn the blue lid of the freshwater tank when closing, as it loosens and can slip off in this case. Please always check the lid for a firm fit.

The freshwater tank has a drain valve (see picture below, red arrow) that can be used to empty the tank underneath the vehicle. If you open the valve to the first resistance, i.e., turn it counterclockwise, the tank empties up to a residual volume of approx. 20 liters. Please note that this volume (and thus also weight) is also the volume indicated when calculating the vehicle weight in running order. Therefore, we generally recommend that you fill the freshwater tank only at the destination and not before the start of the trip.



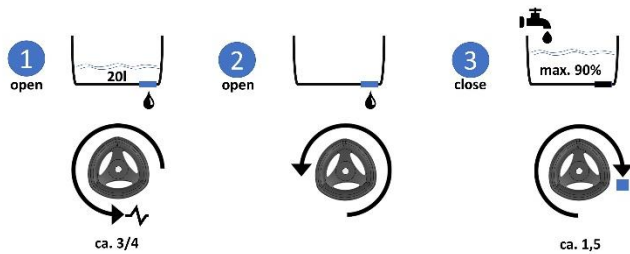

A further rotation of the drain valve by approx. 1/2 rotation then leads to a complete emptying.

In the freshwater tank there is a cartridge for drinking water preservation of the company Certec. According to the manufacturer, this lasts up to 12 months. Please remember to replace it after this time at the latest to ensure the correct functioning of the freshwater preservation.



Optional (possibly additional) underbody fresh water tank

Optionally, the Alphavan can also be delivered with a (possibly additional) underbody fresh water tank.

The underbody fresh water tank with a capacity of approx. 105 litres has an electronic drain valve so that the tank can be emptied electrically via the MBAC.

In addition, this tank has two screwable inspection openings on the bottom, which can be used to open the tank completely, e.g. to clean it manually.

Due to the installation in the outdoor area, the underbody fresh water tank is supplied with two heating elements. These can be activated and deactivated via the MBAC during the cold season. By means of a mechanical element, these heating elements are heated with electricity when the temperature drops below about 5°C. Conversely, this means that the heating elements are not

energized when it is >5°C, even though the heating elements are shown as active in the MBAC.

Important note: The outer tanks are particularly susceptible to frost due to their outdoor location. It is therefore important to ensure that the water is drained during appropriate cold temperatures in order to avoid damage. Especially at temperatures below approx. -5°C, there is an increased risk of frost, even despite the installed heating probes.

If you have integrated the underbody fresh water tank in addition to the standard tank in the FlexPort, there are some specifics to consider (please also see below schematic figure):

1. The underbody tank is filled via the regular drain valve of the internal fresh water tank (see description above on how to open it). By leaving this drain valve permanently open, fresh water always flows from the internal tank into the external tank. Important note: if you leave this drain valve open permanently, then the Y-pipe construction in front of the water pump must be adjusted so that the water pump always sucks water from the lower tank.
2. By using the two tanks in combination, the overall system can also be adjusted in such a way that the external water tank is not used during the cold season. Then the drain valve of the inner tank simply has to be closed permanently and the Y-piece on the hose in front of the water pump has to be adjusted so that water is only sucked in from the inner tank.

Important note: Under all circumstances, it must be ensured that one of the supply lines to the water pump is open when it is in operation. Otherwise, there is a risk of damage to the water pump.

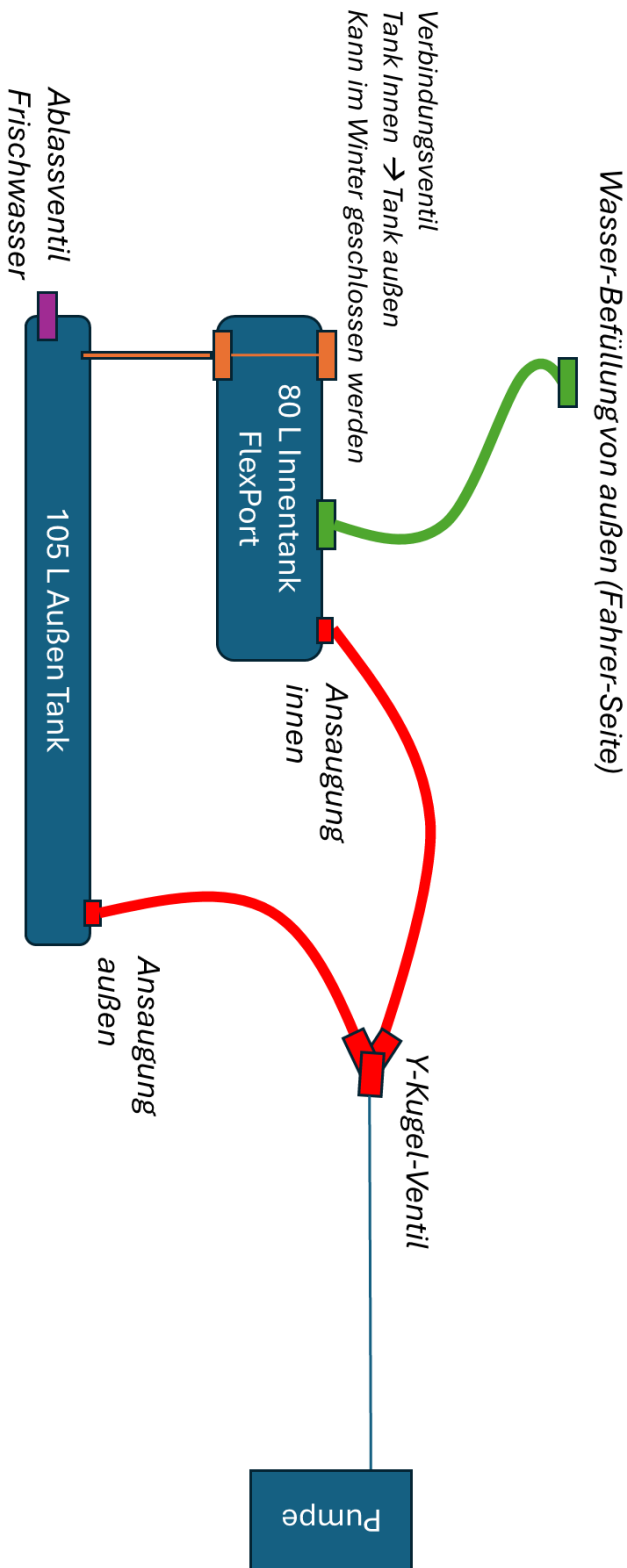

Important Note: If the vehicle is not in use for several days or is not heated in case of frost, please empty the entire water system. Leave the taps open in the middle position. In this way, frost damage to the built-in devices, frost damage to the vehicle and deposits in water-bearing components can be avoided.

Important note: The outgoing grey water pipes that flow into the grey water tank have a maximum approved temperature value of 50° C. It is therefore absolutely important to ensure that water that is not too hot when filled into the grey water system in order to avoid damage. In particular, it is not possible to empty boiling water in the kitchen into the drain. This leads to damage to the grey water pipes!

Water pump: In-water submersible pump

Since the beginning of 2023, the Alphavan can also be equipped with a pressurized fresh water pump – in this case, please jump directly to the following chapter.

In the fresh water tank there is a high-performance submersible fresh water pump, which builds up the water pressure via a powerful integrated motor and thus ensures the water supply in the Alphavan.

Important note: the suction opening of the water pump at the bottom ("grid opening") must always be kept open and care must be taken to ensure that no parts are introduced into the fresh water tank. For example, even with disinfection tablets used, make sure that no loose papers or strings remain in the fresh water tank.

Important note: It is essential to ensure that the pump is deactivated again after use and does not run permanently. Otherwise, there will be damage to the water pump due to running too long.

Important note: If the pump is used improperly, it can be damaged, for example, by overheating, i.e.

Watersystem: water pipes fresh water and grey water

The water pipes in the Alphavan run from the water pump to the rear (outdoor shower FlexPort) or to the front (shower / bathroom / kitchen).

especially during dry running or too long a duty cycle of the pump. The maximum endurance of the pump should be 10-12min. Do not exceed.

Water pump: Pressurized pump

Since the beginning of 2023, the Alphavan can be equipped with a pressure pump. This pump is located in the FlexPort on the driver's side, at the location of the rear wheel (across from the Mercedes-Benz Advanced Control). To get access to the pump, remove the cover panel in the FlexPort on the driver's side (ideally with two people, one person levers in front, one person levers out at the back).

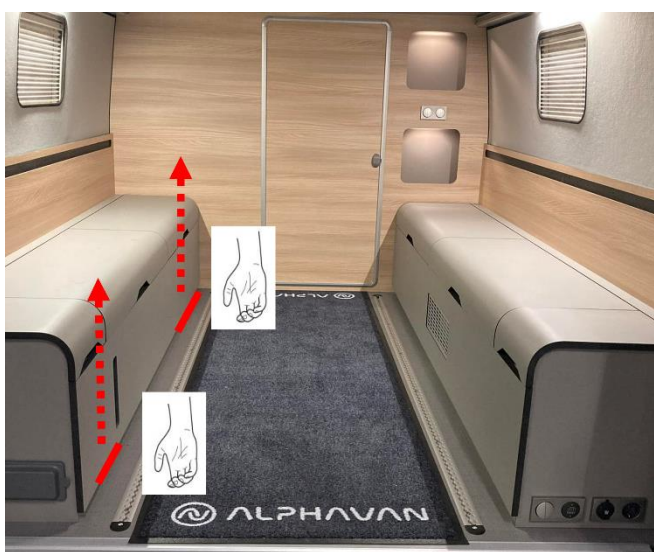

Important note: The water system in the Alphavan is designed for a maximum water pressure of 2.5 bar, which must not be increased. Otherwise, the water system (e.g. boiler or connection points) might be damaged. Even though the water pressure on the water pump can be adjusted manually, it is always important to make sure that the pressure is not higher than 2.5 bar. If a new pump is to be installed in the future, this specification of max. 2.5 bar must be taken into account.

The pressure pump is always equipped with a pre-filter between the fresh water tank and the pump, which ensures that coarser particles / dirt do not get into the pressure pump and damage it. This pre-filter should be checked and cleaned regularly for proper functioning.

Important note: if you want to remove the pre-filter, precautions must be taken to ensure that no water escapes from the then open pipes. It is recommended to physically block/jam the pipes in front of the pre-filter and behind the water pump. When reassembling, first test the piping system for leaks!

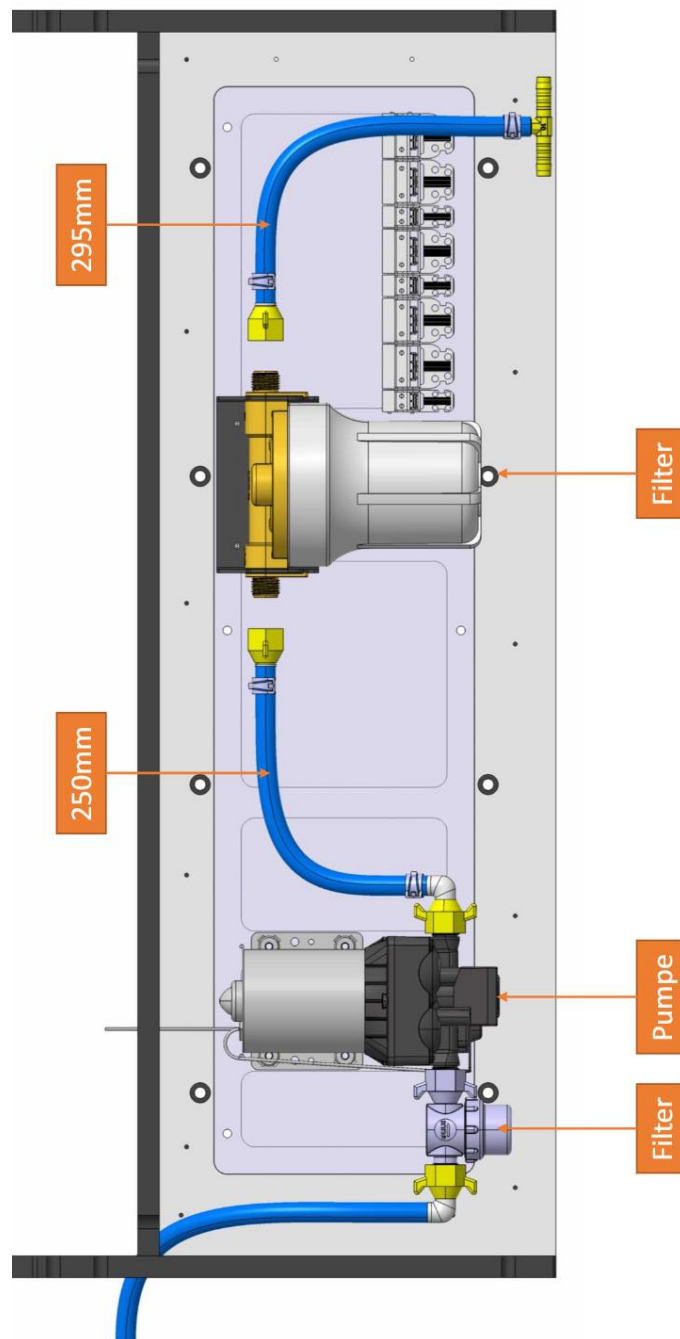

In addition, the system can be expanded with an optional high-performance "inline water filter". This larger filter sits "behind" the pump in the direction of the living room and purifies the water.

Official indication of the manufacturer for a possible water service life: 15,000 L or 6 months.

The push-and-connect system of the inline water filter ensures that no water can run from the pump or from the direction of the living room when the pipe is disconnected. Note, however, that the filter depot itself is also under pressure and thus water can escape when removed. Always prepare an exchange with enough towels ready to hand.

Important Note: When opening the filter housings of the prefilter or purifying filter for cleaning / exchange purposes and closing it afterwards, it is very important to make sure that the sealing rubber ring (O-ring) is perfectly fitting with the housing so that no water can leak outside. Therefore we absolutely recommend testing the water system for leaking before re-assembling the closing panel. There is a risk of water damage if this is not closed perfectly and concealed thoroughly! Please do not overturn the closing mechanism as this could damage the rubber ring and allow water leakage. The housing must be closed and turned carefully.

The Bioelektro-DEPOT Plus has a special antiseptic and antibacterial effect (very high germ protection, high filter performance, special activated carbon made of organic coconut, integrated aeration function, drinking water certified).

Inline UV Water Disinfection

The optional UV water disinfection unit with LED radiation is located behind the pump in the direction of the living space. The system is operated via a 12V connection and is permanently operational when the 12V supply is active. Operational readiness is signaled by a regularly flashing green LED on the housing.

When the water pump is active, the UV disinfection unit is also activated and emits UV radiation onto the water flowing through it. This activity is signaled by a permanent green LED on the housing.

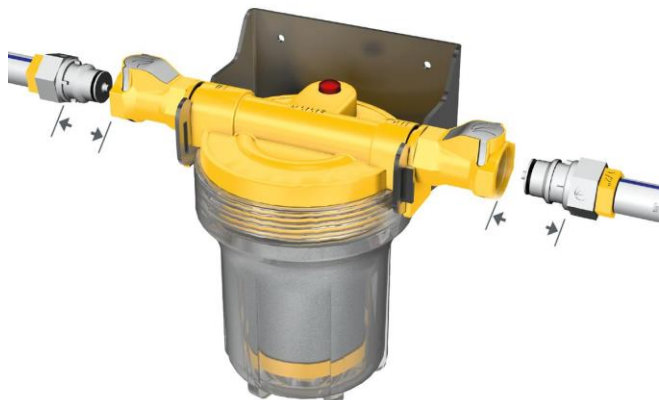

Filter System Inline

The compact filter system "Certec Inline / Certec Ceramic" has a push-and-connect system that enables quick change of the filter cartridges. These must also be changed accordingly with regular use.

Here's how to change the cartridge quickly and easily:

1. With the quick coupling, the filter can be removed quickly, safely and easily
2. Press the white release button on the quick coupling and remove the valve adapter from it.
3. Now remove the entire filter system from the holder by pulling it out upwards.
4. Twist out the filter cup counterclockwise.
5. Now replace the filter cartridge and reassemble the filter cup.
6. Replace the filter system in the holder.
7. Insert the valve adapters into the respective quick coupling until it engages.
8. If necessary, the filter system can then be vented by pressing the red vent button.
9. In the event of longer downtimes, the filter cartridge should be removed and stored in a cool place (e.g. in the refrigerator).
10. Do not use harsh cleaning agents when washing out the filter pot.

If the system has error states (e.g. idle or similar), this is indicated by a red LED. In addition, a corresponding beeping sound can be heard. This can, for example, happen when the water bypass is activated past the system.

Important note: In freezing temperatures, it is essential to ensure that there is no water in the disinfection unit. There is a risk of damage in the event of freezing. To ensure that there is no water in the system, the two hose connectors at the top and bottom of the system must be disconnected so that water can drain downwards.

Overwintering water system and filtration system

Overwintering the vehicle and the water system requires special protective measures in the event of a risk of frost or minimum temperatures, as at temperatures below 0°C the water system could freeze and be damaged if it still contains water.

The frost valve in the Alphavan opens the hose system around the water boiler at the right temperatures. Another possibility is the use of special antifreezes, which, however, must be suitable for drinking water.

If an appropriate antifreeze is used, the filter cartridge in the filter system must be removed from the filter housing before use.

However, even without antifreeze, the cartridge must be removed from the filter system, otherwise it could be damaged.

Without antifreeze in the water system, the following points must be taken into account:

1. Disable fresh water pump via MBAC
2. Empty the fresh water tank completely via the drain valve provided for this purpose, so that the fresh water in the fresh water tank cannot freeze.
3. In addition, at such temperatures, the taps in the kitchen and bathroom must be "opened" in the middle position so that

there is no pressure on the pipes and any water still present in the pipes can expand.

4. If your vehicle is equipped with a pressure pump and an appropriate filter system, the filter containers must be opened and emptied so that the water in the two filter housings (small pre-filter and larger activated carbon filter) does not freeze.
5. Empty the grey water tank completely via the manual valve

Important note: If you have parked your vehicle at such low temperatures without emptying the filter containers, we strongly recommend that they are checked for leaks and damage before you put the water in the Alphavan back into operation.

Wastewater Tank/ Greywater Tank

The water tank is in the substructure of the Alphavan in the middle of the driver's side. It has a volume of approx. 80 liters.

In the grey water tank, all wastewater from the wet room and kitchen is collected. Please empty the wastewater tank only at designated and approved emptying points.

The valve of the wastewater tank can be opened electronically via the MBAC for emptying.

Important note: When emptying via the electronic drain valve via MBAC, a residual volume of about 10 liters remains in the tank because the electronic drain valve is mounted on the side of the grey water tank.

Note: In the past, an Alphavan customer has had the electronic drain valve change its original closing setting over a longer period of time with major temperature differences, so that the valve had no longer closed completely. In such a case, the valve can be tightened manually by first pulling out the locking cylinder provided for this purpose (approx. 5mm), then turning it clockwise to a stop and finally pushing it back in and locking it again. The yellow electronic drain valve is located on the grey water tank on the side facing the rear of the vehicle.



Of course, the wastetank can also be completely emptied. This must be done manually by pulling the red slider below the driver's side of the vehicle in the middle (below the left living room window) towards the outside. Beforehand, the cover cap on the opening valve below the vehicle must be removed.

Note: We generally recommend the complete emptying of the wastewater tank during longer standstill periods (hygiene).

Note: We have integrated an overflow protection in the wastewater tank, but regular emptying is recommended, especially in the cold season, so that the grey water does not freeze.

Note: The level sensor in the greywater tank is subject to mechanical fluctuations and can provide implausible values especially if regular cleaning is not observed.

Important note: The weight of the Alphavan in ready / drive off condition is calculated with an empty greywater tank. Therefore, it is recommended to empty the grey water tank before each trip. A filled greywater tank reduces the possible permissible payload of the vehicle.

Important note: The grey water tank must be cleaned regularly and intensively (approx. 2-3 times a year) when in use. Otherwise, stubborn dirt can form, which is deposited both at the bottom of the grey water tank and at the level sensor of the grey water tank and the openings. This can cause damage to these areas. In particular, the level sensor in the greywater tank is a sensitive sensor and can be damaged by not cleaning the tank regularly.

Voltage Converter DOMETIC DSP 2312T for operating 230V Devices

In the Alphavan, 230V sockets are placed in various places. Accordingly, you can also operate the devices from your household in the Alphavan without special adapters. In addition, the induction cooker, and the air conditioning in the Alphavan are also operated via 230V voltage.

For this purpose, we have installed a high-quality voltage converter from Dometic, which can provide a maximum power of 2300 watts.

If you use the Alphavan without externally connected landline power, the voltage converter must first be switched on before you can operate appliances at the 230V sockets or cook/air condition.

In addition, at the control panel in the living area (see below) the voltage converter can also be switched on and off separately on the device itself - in the FlexPort in the trunk at the front on the passenger side.



For this purpose, there are three modes that can be set via the switch above the blue LED.



- OFF (middle position of the rocker switch): The device is completely switched off and, in this mode, also cannot be activated via the control panel in the living area. This mode is suitable for longer standstill periods. Important note: Please switch the device into the "0"/Off position for longer periods >3-4 days in order not to discharge the battery. Also make sure that the MBAC display is not set to continuous operation.
- ON (top position of the rocker switch): The device is permanently switched on and thus consumes energy permanently – it cannot be switched off via the control panel in the living room in this mode. We do not recommend this setting.
- REMO (lower position of the rocker switch): This so-called "remote" mode allows activation and deactivation via the control panel in the living area and is the recommended setting for normal use of the Alphavan during an operating phase. This setting is also the setting at vehicle handover.

If the rocker switch is in the "REMO" position, the control panel to the left of the MBAC display can be activated above the sliding door on the passenger side by pressing the command dial once – the display then starts automatically.



Also, additional information can be requested via the control panel. If the dial is turned e.g., in the second menu, the current energy consumption in the 230V network (in watts and amps) in the Alphavan is shown.

Important note: We recommend that when not using the 230V sockets or air conditioner/induction cooker, the voltage converter is switched off because the voltage converter continues to consume energy to maintain the 230V outlets. To do this, the command dial must be held down for a long time (about 4 seconds). The display then turns off. If the display does not reactivate when the rotary wheel is rotated, this is the sign that the voltage converter is switched off.

Otherwise, a constant power consumption takes place via the on-board battery and thus a discharge.

For a longer standstill period (from approx. 4 days), please switch off the voltage converter completely via the rocker switch on the device itself to the middle position "OFF", so that the complete energy consumption is prevented.

Note: The control panel of the voltage converter switches off automatically even in the active state after a certain time without input, although the voltage converter is still active. To ensure that the voltage converter is no longer active, the display must not start when the rotary dial is turned.

Note: If you disconnect the vehicle from landline power, the voltage converter normally remains on. In this case, too, it is advisable to check whether the display is not activated when the rotary wheel is turned to ensure that the voltage converter is really deactivated.

Here you will find some original excerpts and explanations from the Dometic instructions for use:

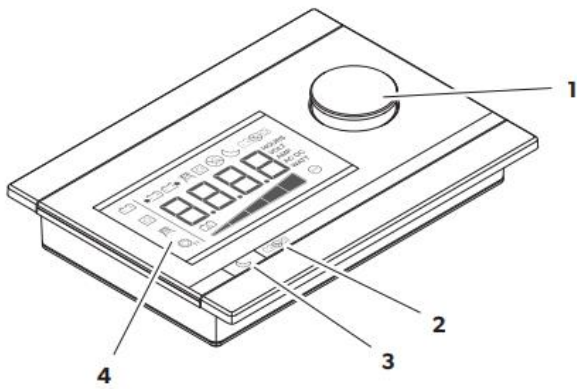

1	Auswahlknopf	Drehen: Navigieren in Menüs oder Werte ändern Drücken: Auswahl von Menüelementen oder Werten
2		Bei angeschlossenem Wechselrichter: Deaktiviert die Wechselrichterfunktion und damit die Stromversorgung von der Batterie zu den 230 V Verbrauchern. Die Batterie wird nicht über den Wechselrichter entladen.
3		Bei angeschlossenem MCA-Ladegerät: Schaltet den Nachtmodus des angeschlossenen Gerätes ein oder aus. Der Ladestrom des angeschlossenen Gerätes wird begrenzt und der Ventilator schaltet sich ab.
4	Display	Zeigt Werte und aktuelle Zustände der angeschlossenen Geräte an.

Symbol	Menü
	Batterie wird geladen
	Batterie wird entladen
	Wechselspannungsnetz ist angeschlossen
	Wechselrichter ist in Betrieb Verbraucher können angeschlossen werden Bei einem Netzausfall übernimmt der Wechselrichter die Versorgung der Verbraucher über die Batterie
	Energiesparmodus ist ausgeschaltet
	Das Ladegerät arbeitet im Nachtmodus
	Wechselrichter ist ausgeschaltet 230 V Verbraucher werden nur über das Stromnetz versorgt

Bewegen Sie sich durch die Menüs wie folgt:

- Drehen Sie den Auswahlknopf (Abb. 2 1, Seite 3), um durch die Menüseiten zu blättern.
Das Drehen des Auswahlknopfes funktioniert in beide Richtungen. Wenn der letzte Menüpunkt erreicht wird, springt die Anzeige zurück zu dem ersten Menüpunkt.
- ✓ Das Symbol des gewählten Menüs (Abb. 5 1, Seite 5) wird angezeigt.
- ✓ Der erste Wert wird angezeigt (Kapitel „Menüs“ auf Seite 24).

Drücken Sie den Auswahlknopf, um den nächsten Wert anzuzeigen.

Die folgende Abbildung zeigt, wie Sie im Menü navigieren können:

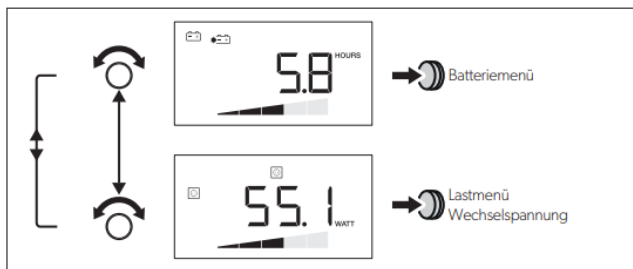

- Drücken Sie den Auswahlknopf, um den nächsten Wert des aktuellen Menüs anzuzeigen (Kapitel „Menüs“ auf Seite 24).

Wechselrichter ein-/ausschalten

- Drücken Sie um den Wechselrichter auszuschalten.
- Drücken Sie erneut um den Wechselrichter einzuschalten.

Display einschalten

Das Display schaltet sich nach einer definierten Zeit ab.

- Drücken Sie den Auswahlknopf oder oder , um das Display zu beleuchten.

Please note that the button 2 (see also picture below) can also be pressed accidentally and thus the 230V power supply can be deactivated. You can see this by the fact that while landline power is unplugged, 0V is always displayed in the menu and the corresponding icon is visible at the top of the status bar of the control panel.



Note: The table in Annex 1 can be used to determine by way of example how much battery capacity is required over time by a consumer (induction cooker or air conditioner).

Electrical operation and control center in the Alphavan

The electric control panel of the Alphavan is in the FlexPort on the passenger side in the front floor trunk. In this center most fuses and the DOMETIC voltage converter (lying, top) can be found, and behind a panel the MBAC module, the charger "Votronic Triple Charger" (standing in front, according to graphic below) and the SuperB battery in a compartment behind the charger are located.

Other special fuses (e.g. for the steps on the sliding door and, if necessary, driver/passenger doors or additional air springs) are located in the driver's seat box. From production 05/2024 onwards, these will be positioned according to the overview in Annex 4.

Note: The majority of the components in the electrical control center (e.g. 12V fuses, various relays, Mercedes-Benz Advanced Control control unit, etc.) are located around the lower part of the

electronics control panel (below the voltage converter). In order to access these devices, the front cover panel of the trunk must first be removed. This panel is locked over several latching noses and can be levered out by pushing it up parallel at the front and back – ideally remove it with two people. As soon as the panel has been lifted upwards, the complete installation level comes to light.



A 12V ON/OFF switch can be used to switch off the 12V supply for the 12V consumers (e.g. Mercedes-Benz Advanced Control, refrigerator, mechanical systems, water pump, heating, etc.) completely e.g. during a longer standstill period. By pressing lightly and turning the knob to "OFF", the supply is switched off accordingly. To reactivate the supply, turn the switch back to "ON".



In newer vehicles, another button is now installed, with which cuts the power supply of the battery itself. The button must be pressed into the direction of "OFF" (in this case a clicking sound can be heard and the switch goes back into the

neutral position) to deactivate the battery supply and into the direction of "ON" to activate it again. An audible "click" sound confirms the successful activation or deactivation of the battery.

An annotated overview of the devices in the electrical control center can be found here:

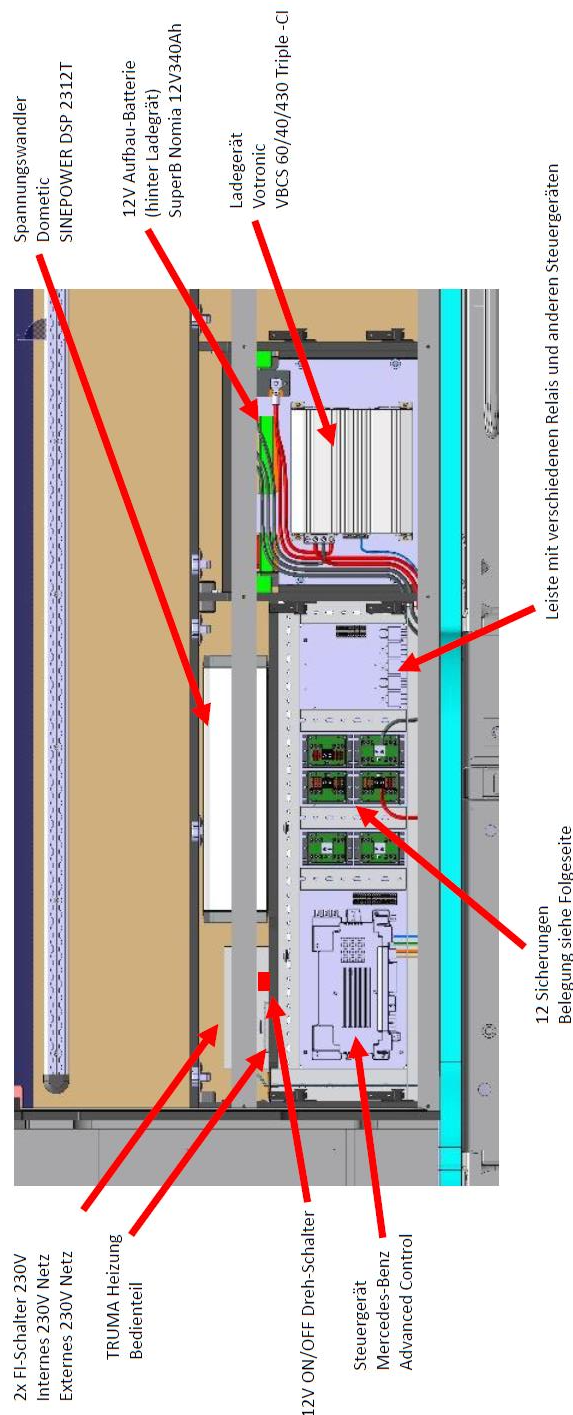

The overview plan of the general fuses can be seen here and again in a large version in Appendix 2:

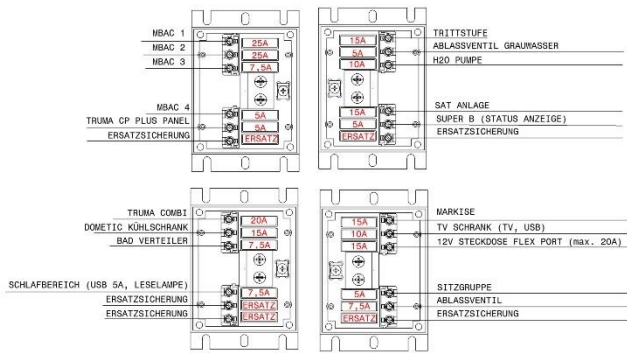

Air Conditioning DOMETIC FRESHJET

For air conditioning of the Alphavan on hot days, we have integrated a high-quality air conditioning system from Dometic.

This air conditioning system is located on the roof in the middle of the vehicle and can be controlled via the MBAC unit or via the remote control or partly on the device itself.

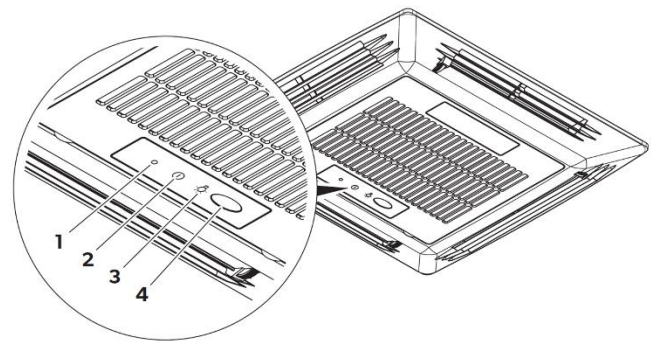

If you operate electrical devices on the 230V outlets that have fault conditions or are not designed for operation via our voltage converter, it may happen in rare cases that the 230V circuit breakers trigger (left: 230V external landline power, right: 230V supply via voltage converter internally). In this case, the 230V fuse can be reactivated in this control panel.

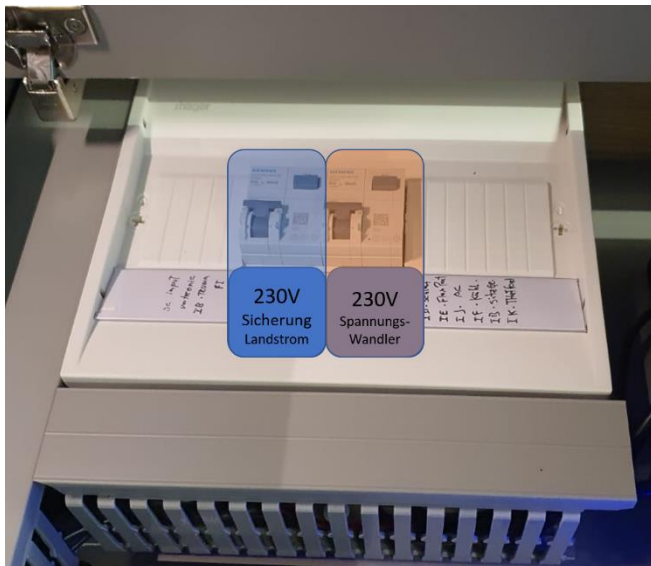

To use the air conditioning, you must first switch on the voltage converter.

The air conditioning has different modes and allows e.g. the setting to a temperature to be controlled or the activation of a recirculation mode. In addition, ambient lighting can be activated directly on the device.

In the air conditioning system, the openings for the air outlet can also be regulated and, if necessary, adjusted differently. When delivering the Alphavan, we always adjust it so that the air outlet to the front and rear is open.

The current consumption of the air conditioning system during cooling operation is approx. 2.7A.

Important note: If you operate via the voltage converter (no external power source available), the following procedure has proven to be optimal in terms of optimal energy consumption: Operate the air conditioning system approx. 10-15 min. in "Cooling" mode and then switch to "recirculating air" mode to save battery capacity. In "recirculating air" mode, the air conditioning system consumes only a fraction of the energy than in "cooling" mode.

Note: All electrical equipment (e.B mobile telephones, radios, televisions, or DVD players) that are subsequently installed in the vehicle and operated while driving must have certain characteristics: these are the CE marking, the EMC (Electromagnetic Compatibility) test and the "E1" test. This is the only way to ensure the functional safety of the vehicle while driving. Otherwise, it is possible that the on-board electronics will be disturbed.

Example consumption: 10 minutes "cooling" consumes approx. 5% of battery capacity. 60 minutes of "cooling" already consumes 30% of the battery capacity.

Refrigerator DOMETIC RC 10.4T

The high-quality compressor refrigerator from Dometic has various cooling programs and a small freezer compartment.

The door of the refrigerator can be opened via the two rails from two sides (i.e., once towards the kitchen, once towards the sleeping area / FlexPort).

Important note: please never put too much weight (e.g. via full bottles) in the refrigerator door in order to avoid damage of the opening mechanism.

Important note: After closing the refrigerator, please make sure that the door lock is completely locked again (if necessary by pressing from the outside), so that the refrigerator door is not completely suspended when reopened or opened from the other side.

Important note: the precision mechanical opening mechanism for controlling / locking the refrigerator door from both sides is located in the frame of the refrigerator door at the top and bottom. The opening is realized via various spring systems. However, these spring systems are sensitive to sticky liquids / residues. Therefore, it is absolutely to be avoided that sweet drinks or alike (such as orange juice or cola) leak in the refrigerator and thus possibly in the worst case make for the way into this mechanism. The operation of the refrigerator would then be noticeably cumbersome or no longer possible at all.

If the door is unlocked from both sides at the same time and the resting noses in the interior of the refrigerator are in special unfavorable positions, it may happen in rare cases that the entire refrigerator door folds out or is loose.

In this case, please proceed as follows according to the manufacturer's instructions to properly lock the refrigerator door again:

- 1) Locate four small movable plastic pins on the inside of the door and fix them in the retracted position with an adhesive tape.



- 2) Replace the door in the state with fixed pins and snap both sides over the handle rails.
- 3) Remove the tapes on all four pins.

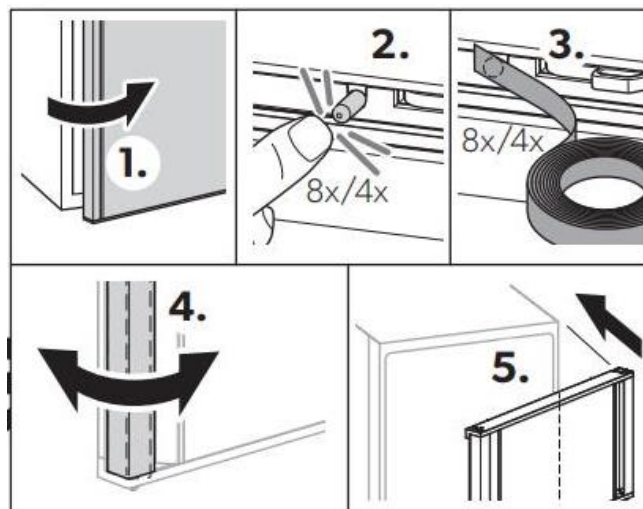

Thetford Induction Cooker

So that you can enjoy even more independence from certain energy sources in the Alphavan, we have integrated a high-quality induction cooker.

If there is currently no external landline power available, the induction cooker can be operated via the voltage converter and the auxiliary battery. To do this, please make sure that the voltage converter has been switched on beforehand.



Please switch on the cooker via the on/off panel and adjust the step of the respective cooker via the +/-fields.

The induction cooker can be operated in different ways – which differ in different energy requirements. However, since the cooker is one of the larger electrical consumers, it is recommended to disable other electrical consumers while cooking. The current electrical power can be called up via the display of the voltage converter. When operating additional electrical consumers in parallel while cooking with the induction cooker, the electrical power may be too high, and the voltage converter would shut down.

Important note: Please make sure that the display of the voltage converter never shows more than a maximum of 2000 watts and pay attention to the wattage displayed in the display when cooking.

Important note: If the load is too high, especially >2000 watts, the voltage converter switches off automatically.

We therefore recommend the following use of the induction cooker when cooking:

- Use of the large cooker plate up to a maximum of level 11. In this stage, a power of about 1300

watts is called up and the subjective cooking power is at the highest level. When activating level 12, 1900 watts of power is called up, while subjectively the cooking power is very similar to level 11.

- Use of the small cooker plate up to level 11. In this stage about 700 watts are needed and cooking on both plates (with level 11 of the large plate) works perfectly

To give you an approximate estimate of how long you can cook with the battery when standing independently without landline power, we have listed an approximate consumption bill from our own tests: if 10 minutes are cooked with both hobs (large plate level 11 and small plate level 11) 2000 watts are permanently required. This corresponds to 32Ah and 15% of the battery capacity.

Please use suitable cooking pots or pans on the induction cooker. You can recognize these by the following sign, among other things:

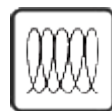

For people with implanted pacemakers, the manufacturer's precautions must be followed, as the magnetic field emanating from the induction cooker may interfere with the function of the pacemaker. If necessary, a consultation with the family doctor should be made.



Heating and Hot Water- Truma Combi 6D E Heater

A Diesel/electric combination heater from Truma was integrated to heat the vehicle and prepare hot water.

When operated without an external power connection, Diesel from the vehicle Diesel tank is

used to heat the vehicle. It is ensured that the Diesel tank of the vehicle is never completely emptied, and that the vehicle can still be moved. If the heater does not have enough fuel, it would stop with an error message on the Truma panel (see below).

At the same time, the heating on an external power supply supports a parallel electric heating mode, which reduces Diesel consumption. In various tests with the Alphavan, it has been found out that using exclusively electric auxiliary heating works well at an outside temperature of up to approx. 7°C.

Important note: If you set the hot water preparation via the MBAC with external power supply, the Diesel operation of the heater is activated automatically. When operating on the TRUMA panel, this condition can be avoided.

The heating can be controlled via the MBAC system or via the Truam panel in the FlexPort (in the cabinet on the co-driver side). In addition to the activation and selection of the primary energy source, a time control can be programmed so that day and time-exact settings can be made.

If the heater detects an error, it switches off and a general error message is displayed in the message center of the MBAC display. A specific error code is displayed on the Truma control panel in the FlexPort in the first trunk on co-driver side. Most of the error or warning codes have to be acknowledged by the user on the Truma panel before the regular operation of the heating system can be restarted.

Among other things, the heating switches off automatically (or does not even turn on) when the heating is activated with Diesel fuel, while the window at the front of the seating area is open. The reason for this is the placement of the exhaust near the window. To be able to operate the heating, this window must always be kept closed.

In case of error conditions, a general error message appears on the MBAC display "Please check the device.". To obtain further information about this

error message, the TRUMA control panel in the FlexPort must be checked in the trunk on the passenger side for further error analysis – a dedicated error code.

Another known error when the heater is set to electric mode and the external power supply stops or is disconnected. In this case, the energy source for the heating must be readjusted. Even if you had already switched back to Diesel operation, please acknowledge the message on the Truma panel.

Some errors must be confirmed by briefly tapping the error code with the dial on the TRUMA display, others can only be deactivated by long pressing the rotary control and restarting the heater.

All TRUMA error messages are described under <https://www.truma.com/de/de/faq/fehlercode-auswertung> and provide an indication for further error analysis. In case a TRUMA error cannot be clarified with Alphavan over the phone, any TRUMA authorized dealer or workshop will have the possibility to inspect the heater system.

The TRUMA control panel can also be used to visualize and control all functions of the heating system.

The ECO indicator indicates that the hot water preparation is activated at 40°C or at HOT at 60°C.

A "flash" symbol means electrical support up to 900W and two "flashes" mean electrical support up to 1800W.

Recommendation: with regular use of the TRUMA heater, it is recommended to operate the heating once a month for one hour under full load (30 °C with the sliding door open) to burn the diesel burner free.

Here are some excerpts from the TRUMA manual for the control panel.

Anzeige- / und Bedienelemente



- 1 = Anzeige
- 2 = Statuszeile
- 3 = Menüzeile (oben)
- 4 = Menüzeile (unten)
- 5 = Anzeige Netzspannung 230 V (Landstrom)
- 6 = Anzeige Zeitschaltuhr
- 7 = Einstellungen / Werte
- 8 = Dreh- / Drückknopf
- 9 = Zurück-Taste

Mit dem Dreh-/Drückknopf (8) können Menüs in den Zeilen (3 + 4) angewählt und Einstellungen vorgenommen werden. Die Anzeige erfolgt über ein Display (1) mit beleuchtetem Hintergrund. Mit der Zurück-Taste (9) erfolgt der Rücksprung aus einem Menü.

Dreh- / Drückknopf

Mit dem Dreh-/Drückknopf (8) können Sollwerte und Parameter angewählt, geändert und durch Antippen gespeichert werden. Angewählte Menüpunkte blinken.



Drehen nach rechts (+)

- Menü wird von links nach rechts durchlaufen.
- Erhöhen von Werten.

Drehen nach links (-)

- Menü wird von rechts nach links durchlaufen.
- Absenken von Werten.



Antippen

- Übernehmen (Speichern) eines angewählten Wertes.
- Auswahl eines Menüpunkts, Wechsel in die Einstellenebene.



Drücken (3 Sekunden)

- Hauptschaltfunktion EIN / AUS

Zurück-Taste

Durch Drücken der Zurück-Taste (9) erfolgt ein Rücksprung aus einem Menü und Verwurf von Einstellungen. Das bedeutet, die bisherigen Werte bleiben erhalten.

Note: It is possible to operate the heating only electrically via an external power source (e.g., at the campsite) to maintain a preset temperature (such as 20°C). But please be aware that in that case the warm water operation should be switched off to prevent the Diesel operation to start.

Due to the very good insulation of the Alphavan, it has been shown in many tests that the set heating temperature can be reduced to about 17-19° C during operation at night.

Note: Do not operate the heater with Diesel fuel indoors. Risk of suffocation!

Important: The exterior window on the 2-seater bench has a so-called window switch. This prevents the Diesel heating from being operated when the window is open, because the exhaust chimney of the Diesel heater sits beneath the window. Therefore, please make sure that the window is closed if the heating is to be operated with Diesel.

To control the heating temperature, a temperature sensor is integrated in the interior wall behind the 2-seating group. Please make sure that this sensor is not covered/disguised.



The boiler for hot water preparation can also be controlled via the MBAC. You can choose between warming up to 40°C or 60°C. The boiler has a capacity of about 10 liters. According to the manufacturer, the heating time of the water tank from about 15° C to 60°C is about 20-30 minutes.

Note: For longer standstill periods especially in winter, it is recommended to open all water taps in the Alphavan so that the water can spread and does not cause damage to the pipes.

Important: Do not use the space above and behind the heating under the 2-seater seating group as storage space. There is a risk of fire!

Frost Valve / Safety Valve / Drain Valve

A frost / safety / drain valve is integrated into the Alphavan, which opens the drain at low temperatures in the vehicle to prevent frost hazards. In addition, the valve is opened if the water pressure in the vehicle is too high (approx. 2.8 bar water pressure).

Note: At internal temperatures in the vehicle below 3-4°C, the so-called "frost guard" of the heater opens and empties the water in the pipes and in the boiler to prevent frost damage. Please note that the water pump also removes the water from the freshwater tank.

This mechanical frost valve must be manually closed again after activation if the water system is to be put into operation. For this purpose, the ambient temperature must be heated up to about 7 °C.

Important note: The ambient temperature of 7°C must really be reached around the frost valve. Even if the perceived or measured temperature in the interior of the Alphavan is already noticeably higher, this may not be enough to be able to engage the frost valve again. It is therefore advisable to open the front flap of the frost valve when heating up and set the temperature higher so that the entire interior warms up quickly.

To prevent the frost valve from triggering at cold temperatures and emptying the water from the boiler and water tank, the heating can be set to a temperature of 6°C so that the temperature and the frost valve do not fall below the 3-4°C limit. In heating mode, the so-called Frost Control heating element ensures that the frost monitor is also

heated and does not trigger. Please ensure in this situation that the warm water is not activated.

Note: Please note that the heater in the "anti-frost" 5°C heating mode described above consumes significant electrical energy (approx. 1-2 kW per day). With a power setting of 900W heating power, double-digit kilowatts come out even with a shelter in a hall over the month. Therefore, it is important to reconsider whether you prefer to empty the water completely in advance instead of letting the heating run permanently if you have a longer standing time in the cold season.

Note: The frost valve is located on the seating area and can be reached via a serviceflap on the front of the seating area (held by magnetic inlets). Below you will find the manufacturer's description with manufacturer image.

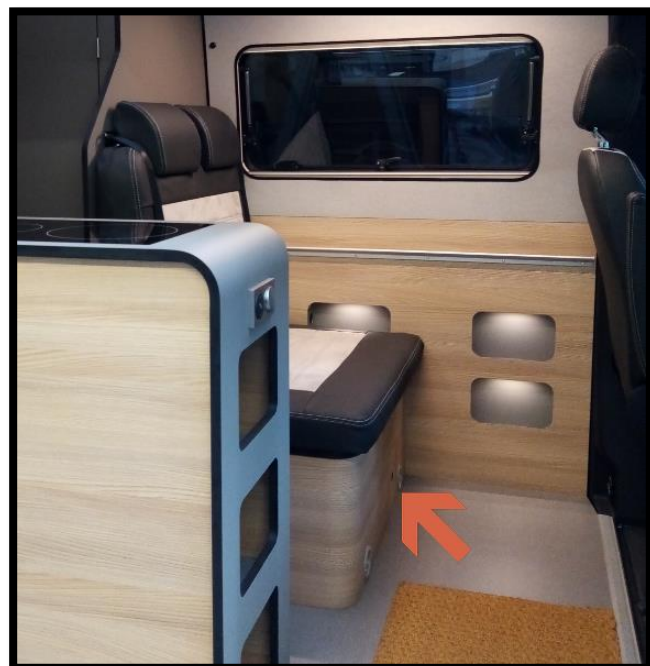

FrostControl (Sicherheits-/Ablassventil)

FrostControl ist ein stromloses Sicherheits-/Ablassventil. Es entleert bei Frostgefahr automatisch den Inhalt des Boilers über einen Entleerungsstutzen. Bei Überdruck im System erfolgt automatisch ein stoßweiser Druckausgleich über das Sicherheitsventil.



Bild 3

- a = Drehschalter Stellung „Betrieb“
- b = Druckknopf Stellung „geschlossen“
- c = Druckknopf Stellung „entleeren“
- d = Entleerungsstutzen
(nach außen durch den Fahrzeugboden geführt)

Öffnen des Sicherheits-/Ablassventils

Den Drehschalter um 180° bis zum Einrasten drehen, dabei springt der Druckknopf heraus (Stellung c). Das Wasser des Boilers läuft über den Entleerungsstutzen (d) ab.

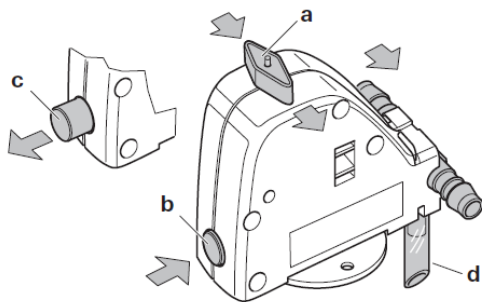
Der Entleerungsstutzen (d) des FrostControl muss stets frei von Verschmutzungen (Schneematsch, Eis, Laub etc.) gehalten werden, um ein sicheres Abfließen des Wassers zu gewährleisten! **Kein Garantieanspruch für Frostschäden!**

Schließen des Sicherheits-/Ablassventils

Kontrollieren, ob der Drehschalter auf „Betrieb“ (Stellung a) d. h. parallel zum Wasseranschluss steht und eingerastet ist.

Das Sicherheits-/Ablassventil durch Betätigen des Druckknopfes schließen. Der Druckknopf muss in Stellung (b) „geschlossen“ einrasten.

Erst bei Temperaturen über ca. 7 °C am Sicherheits-/Ablassventil kann dieses mit dem Druckknopf (Stellung b) manuell geschlossen und der Boiler befüllt werden.

Heating Operation

Several air outlet nozzles are installed in the vehicle. Appropriate pipes lead the warm air to the air outlet nozzles. All nozzles can be adjusted to adjust both the direction of the air flow and the amount of airflow: Fully opened - full hot air flow and partially opened - reduced warm air flow.

Important Note: Please note that from the air outlet nozzles very hot air can be blown out – therefore, please do not place sensitive objects in front of open nozzles. Please also make sure that there are no Alphavan furniture parts in front of

the outlet nozzles – in particular, the open FlexPort door conceals an air outlet nozzle. If heating is provided and this door is open, this air outlet nozzle must be closed, otherwise there is a risk of damage.

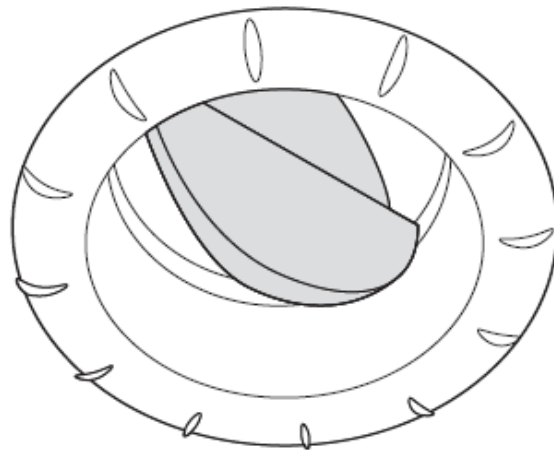

Electrical Awning THULE OMNISTOR 5200

The Alphavan is equipped with an electric awning from Thule.

The awning can be retracted and extended via the MBAC system. In addition, the awning can be retracted and extended via a dedicated switch at the rear end of the FlexPort (passenger side). To start the run-in or extension process, please press the switch once. To interrupt the process, please press it again in the same direction.

Please note that the extension process of the awning must be stopped after an extension length of approx. 1m due to the weight of the pull-out. Then the support feet must be folded out. When retracting, please act accordingly in reverse order.

The support feet are folded in the extendable awning strip at the front end of the awning. These can be easily unfolded after the latch closure has been loosened. The support feet are equipped with height-adjustable rails – these can be fixed in a defined position by locking the two plastic levers

upwards on the frame – for this a certain resistance must be overcome.

With the vehicle we also enclose two herrings for further fixation of the feet of the awning in soft ground. Use these herrings for additional stability.

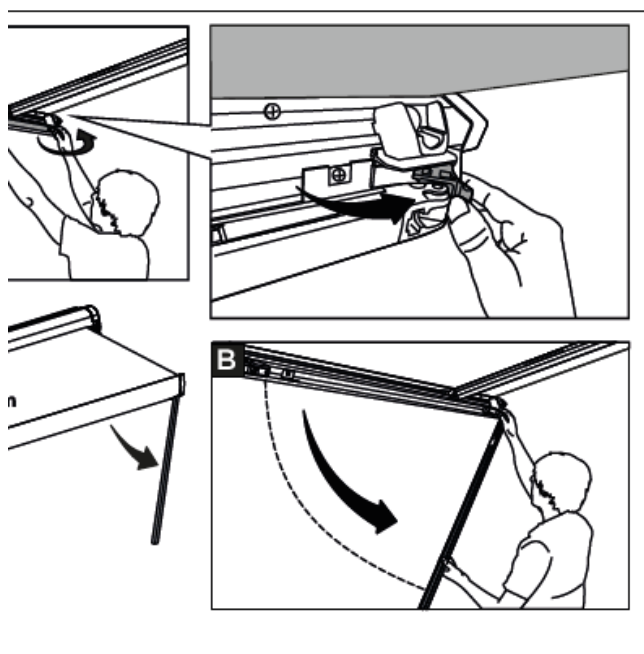
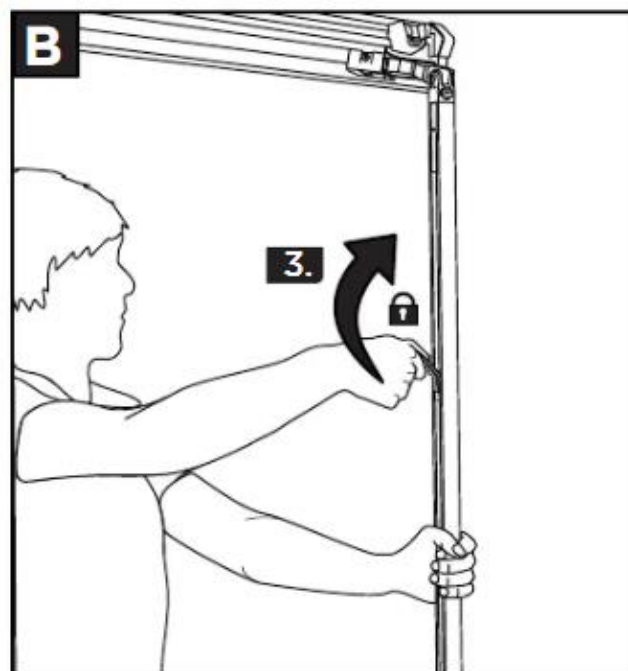
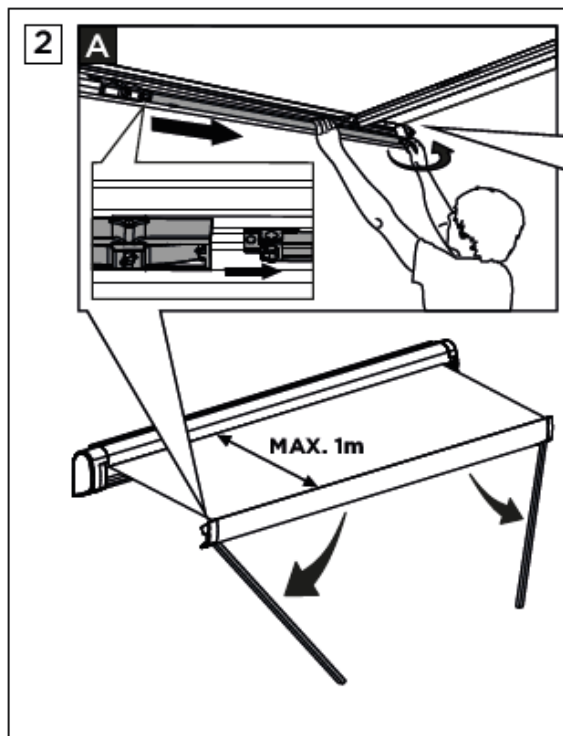
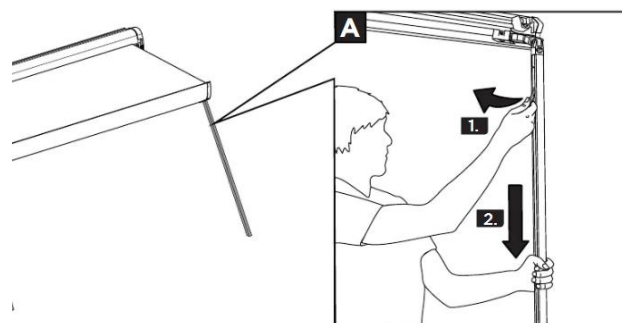

To ensure further stability of the support arms and the support feet, two further stabilizing beams are integrated in the extendable part of the awning. These can be easily removed when extended and snapped into place at the corners of the awning.

Important: Please make sure that these carriers are dismantled before retracting the awning, otherwise the engine of the electronic awning will be damaged.

Important: Please make sure before extending the awning that there are no objects in the extension area of the awning and that in particular the rear load compartment door on the passenger side is not in the extension area of the awning.

Note: In the past, it once happened to an Alphavan customer that the awning could no longer be operated. In this case, it ultimately helped that the fuse of the awning in the electrical control panel

was briefly pulled and then reinserted (fuse assignment see Annex 2) or alternatively, if available, the power-off switch in the electronic control panel was set to "Off" and back to "On".

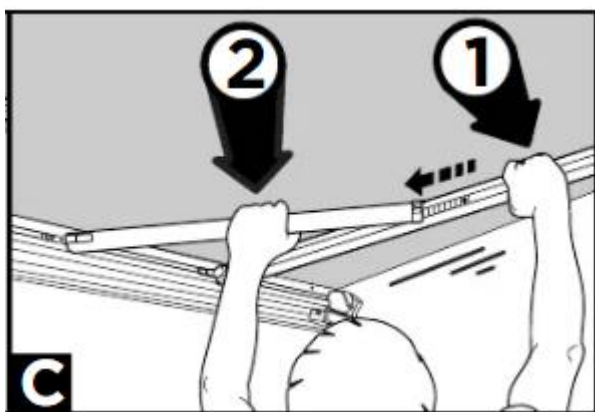
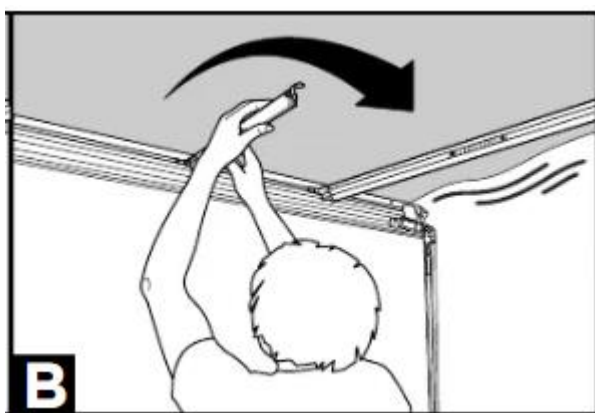
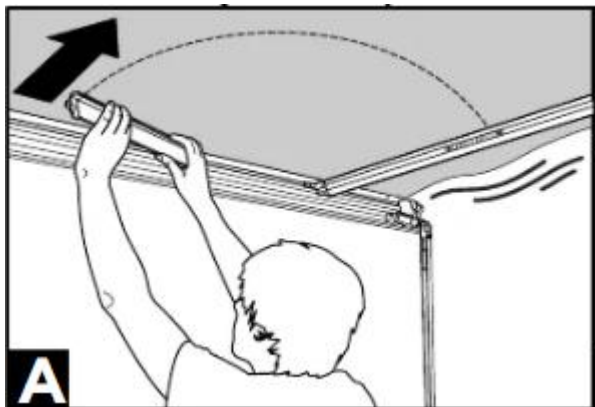

In case of wind, heavy rain or snowfall, the awning should be retracted to prevent damage.

If the vehicle is unattended for a long time, we recommend that the awning is completely retracted, too.

In light rain, we recommend shortening one of the support feet so that the water can drain more easily.

The awning should only be retracted when the cloth is dry. If the awning must be retracted with a wet

cloth: Re-Extend the awning as soon as possible to dry the cloth.

Please remove leaves and coarse dirt from the awning when retracting.

For safety reasons, the operation of the awning only works while the vehicle engine is not active. Please make sure that you retract the awning completely before driving.

Bathroom / Shower

We have focussed on optimal water resistance in the bathroom and shower. In the bathroom, you can easily extend the sink via the push-lock mechanism for use and retract it for space optimization and during showering.

The water armature at the sink is also a shower shower through the extendable pipe. The cable can be extended from the bracket about 100cm.

Note: To remove the shower head, please turn the faucet in the direction of travel and carefully pull out the shower head to the desired length. When moving in, please follow the same procedure in reverse order.

Note: Please activate the water pump via the MBAC system before using the shower.

The shower / bathroom tub of the Alphavan with a heightened side edge is especially suitable for installation in motorhomes. The heightened side edge of the shower tub is underlaid, but is not designed for a load (e.g. standing on the edge). The shower tray is made of stable, smooth and easy-care plastics.

Important note: Please note that the edges of the shower tub are not designed to load them with (body) weight. If the edges are loaded with weight, there is a risk of damage!

The wall of the wet room is highly waterproof. However, we recommend that the the water jet is directed in the corner towards the driver – facing away from the door of the bathroom. Please avoid splashing water in the living area of the Alphavan so as not to damage the floor there. That's why we always equip the Alphavan with a shower curtain when it comes to delivery.

A water-protected compartment is located at the top of the wet room.

Toilet and SOG Ventilation System

In the bathroom there is also a Casette toilet from Thetford. It is equipped with the so-called SOG ventilation system to avoid unpleasant odours.

To use the toilet, please make sure that there are toilet additives in the faecal tank. The SOG vent system is automatically activated by opening the lever (see picture) counterclockwise

To rinse, please press the blue button.



13. Nach der Benutzung öffnen Sie den Schieber (wenn noch geschlossen), indem Sie den Hebel entgegen dem Uhrzeigersinn drehen. Sie spülen die Toilette, indem Sie einige Sekunden auf den Spülknopf drücken. **TIPPI!** Lassen Sie etwas Wasser in die Schüssel laufen, indem Sie den Spülhebel noch einmal auf- und abbewegen oder öffnen Sie den Ventilschieber unter der Toilettenschüssel, indem Sie ihn zu sich hin ziehen. Schließen Sie den Schieber nach der Benutzung.

Achtung! Lassen Sie kein Wasser im Becken stehen, wenn die Toilette nicht benutzt wird. Dies vermindert keine unangenehmen Gerüche und kann lediglich zu Verstopfung führen.

Anmerkung! Um Verstopfungen zu verhindern, empfehlen wir die Verwendung von Thetfords schnell auflösendem Toilettenpapier, Aqua Soft.

Wichtiger Warnhinweis! Bitte reisen Sie nicht mit einem zu vollen Spülwassertank (wir empfehlen, mit einem leeren Tank zu reisen, sicherheitshalber sollte er aber keinesfalls mehr als halbvoll sein). Während der Reise sollte sich auch kein Wasser im WC-Becken befinden. Wenn Sie diesen Hinweis nicht beachten, können Wasserschäden an Ihrem Wohnwagen oder Wohnmobil entstehen. Bitte Fahrt mit einem mehr als $\frac{3}{4}$ -vollem Fäkalientank vermeiden. Das könnte ein Leck durch das Lüftungssystem verursachen.

Note: The SOG venting system generates a vacuum via an integrated electric motor and dissipates unpleasant odors via an active carbon filter at the bottom of the vehicle. When the toilet lever is opened, you can hear that the electric motor is starting to run. According to the manufacturer, the corresponding carbon filter should be changed once a year to ensure proper function. If you notice unpleasant toilet odors in the Alphavan after about a year, this is a sign that the filter should be changed.

Under the name "SOGII replacement filter underfloor variant" this is available in retail shops. To change the filter, open the service flap in the shoe cabinet between the bathroom and FlexPort. The SOG hose must be carefully pulled out of the filter (green cylinder), after removing the old filter, the new filter can be used (see pictures below).

Important: Please note that the black sealing rubber must not be thrown away, but must be inserted / transferred to the new filter when changing.



The faecal tank can be reached on the driver's side from the outside via a corresponding service flap and removed for emptying.

ENTLEEREN

Der Fäkalientank hat einen Inhalt von 19 Litern und muss spätestens dann geleert werden, wenn das rote Lämpchen der Füllstandsanzeige leuchtet. Das geschieht, wenn im Fäkalientank noch ein Rest von rund 2 Litern ist, was +/- 3 Benutzungen entspricht. Es wird empfohlen, den Fäkalientank bereits vorher zu entleeren.

Achtung! Lassen Sie den Fäkalientank nicht zu voll werden.

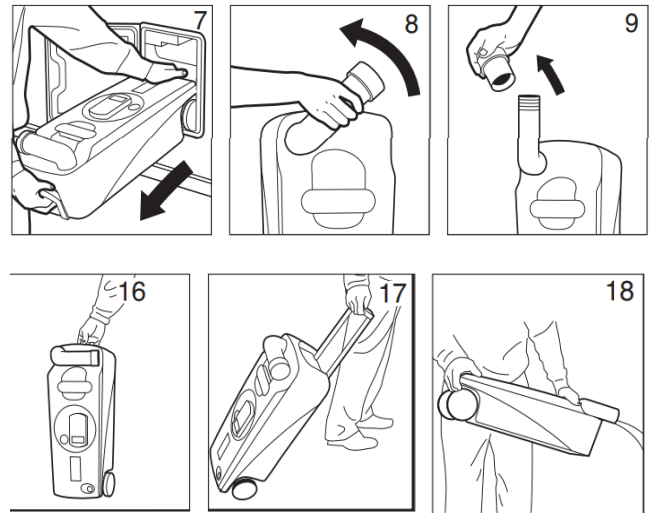



Important note: To turn on the water pump, press the toggle switch downwards and to switch off the water pump, press the toggle switch upwards. After finishing, please make sure that the toggle switch is back in the upper position!

Plug the hose of the shower head into the plug provided for this purpose and regulate the water temperature via the appropriate dial.

Please note that after using the outdoor shower, there is still water in the hose. We recommend a complete emptying of the hose after use and only then a stowage.

Important note: It is essential to ensure that the pump is deactivated after use of the rear outdoor shower and that it does not run permanently. Otherwise, there is a risk of damage to the water pump due to too long running.

Important note: If the pump is used improperly, it can be damaged, for example, by overheating, i.e. especially during dry running or too long duty cycle of the pump. The maximum continuous running of the pump should not exceed 10-12min.

Important Note: When cleaning the outdoor shower appliance / flap make sure that afterwards the water pump is not running to avoid damage of the pump. Whenever you close the flap of the outdoor shower make sure that the water pump is turned off, i.e. the middle switch is in the upper position!

Important note: If you have activated the water pump via the toggle switch (toggle switch in the lower position) and in the next step deactivate the water pump via the display of the MBAC and then activate it again later, this will cause the entire water pump to no longer behave as usual. It should therefore be absolutely avoided to deactivate the water pump via the MBAC before the water pump on the rear shower appliances has not been deactivated (toggle switch must be in the upper position).

Note: Please empty the faecal tank only at designated stations. In the meantime, there are more and more specially designated stations at modern overnight parking spaces and campsites, where the tank can also be cleaned immediately.

Note: Please use only approved toilet additives to clean the faecal tank. We recommend the products of Thetford or Dometic.

Note: After emptying the faecal tank, please make sure that it is properly locked again.

Rear Outdoor Shower and Activation / Deactivation of the Water Pump

In the rear area of the FlexPort (driver's side) we have integrated an appliance for an outdoor shower with hot water. A corresponding shower head with hose is enclosed at delivery of the Alphavan.



To use the shower, please make sure that the water pump has been activated via the MBAC display beforehand and that hot water is prepared if required.

When the middle toggle switch is pressed downwards, the water pump becomes active (you would hear the motor in the water pump of the fresh water tank to become active), and you can use the water via the lever on the shower head.

SAT / DVB-T TV with WiFi Connectivity, Bluetooth Support and WiFi Streaming - TV cabinet

The TV has an on/off rocker switch at the lower edge, which you can use to turn off the TV completely. If you do not see a blue LED on the front of the TV, this is a sign that the TV is completely switched off and must first be switched on again via the rocker switch.

The TV can be swivelled into both the bedroom and the living area and can be adjusted in height. To do this, please first loosen the round lever on the rail behind the TV screen (pull upwards) and then gently swivel the TV from the TV space into the appropriate position. The height can be adjusted via a lever on the vertical mounting rail.

Note: When driving, please make sure that the TV is safely stowed in the TV space and that the mounting lever is locked in place.

Important note: In the TV cabinet behind the swivel arm of the TV there is a service flap, which is intended for service measures. This flap is explicitly not intended as a hidden storage compartment! Parts stored there can fall behind the refrigerator and would therefore no longer be accessible. Therefore, please do not use this service flap as a hidden storage space

If you have installed a SAT system on the roof of the vehicle: To use the combined SAT/TV system, please switch on the TV with the remote control and activate the SAT mode in the menu "Source". As a result, the SAT dish on the roof of the Alphavan extends and will automatically set the correct orientation.

Note: For SAT reception, the SAT dish must be aligned with a sky-solid satellite. Accordingly, a direct line of sight between the dish and the satellite is necessary. Building walls, roofs, mountains, or other obstacles can disturb the reception and result that no reception is possible.

Please check that the satellite system is retracted before the start of the journey. We also recommend that the satellite system not to be used in bad weather and wind to avoid storm damage.

In addition to the actual SAT mode, the TV also supports streaming the SAT content to a device with a supported app. To do this, please download the app "CAPcontrol" from the App Store and establish a

corresponding WiFi connection between the device and the TV. Then you can also enjoy the reception of the satellite channels in front of the Alphavan, within range of the TV WiFi network.

In addition, the Smart TV also supports Internet-based content (e.g., YouTube, Netflix) and can be connected to the Internet via an available WLAN / WiFi network. In the "Settings" menu, a network can be displayed, selected and the relevant password entered. Please note that you may need your own accounts with usernames and passwords for special Internet-based content at the corresponding applications or providers.

Supported Bluetooth devices can also be connected to the TV. The pairing process can be started via the corresponding menu.

If you have chosen the Alphavan with the DVB-T option instead of the SAT option, a DVB-T antenna is installed in the roof area of the rear roof window instead of the SAT system. Freely available TV and radio programs can be found via an automatic station search. Please note that DVB-T reception depends on the location of the vehicle. If you drive the vehicle to a new location, you will probably need to re-enable the automatic channel search to use the locally available TV programs. In Germany, the public channels are usually free to receive.

Note: If you cannot receive any stations, please first check whether the TV is set to the correct media source. Via the remote control you can check with the button "Source" which media source is currently active.

Optionally available Cellular / WiFi Router and 4G/5G/WiFi Roof Antenna

On request, the Alphavan can be equipped with a high-quality combined mobile phone/Wifi roof antenna. In addition to the common 4G (LTE) standard, this roof antenna already supports the 5G mobile radio standard. The four antenna cables (2x mobile communications, 2x WiFi) from the roof antenna are routed along the body into the service compartment behind the TV cabinet. There they are plugged into the high-quality cellular router. Some routers work without the Wifi antennas connected. The router can be

equipped with its own SIM card to enable WiFi Internet connection via a hotspot.

The router has an administration console that can be used to carry out various settings and, above all, the basic setup. Please note the separately enclosed operating instructions for the router for the setup.

Optionally available Starlink Kit

If desired, the Alphavan can be equipped with the Starlink kit. With this kit, a special mechanical holder is integrated into the awning sheet metal on the roof, into which the Starlink satellite dish can be clipped. The mechanism for locking the dish is the same as the mechanism of the original Starlink dish as shipped to end customers.

In addition, pre-wiring for Starlink is installed in the vehicle so that all the necessary cables are laid neatly and hidden. The Starlink router and the satellite dish can then be connected at the outside (roof with awning at the front) and at the inside (belt retractor driver's seat area) using special plugs.

Important: When the Alphavan is delivered, the appropriate cables for connecting the Starlink system are included. Since Starlink has not yet offered any corresponding adapter cables for an installation like in the Alphavan, you would have to order the appropriate sets from Alphavan if you lose or have defective cables/plugs.

To use the Starlink satellite internet, the router must be connected to the connector on the driver's seat and the satellite dish to the connector on the roof. Then the router must be connected to the 230V power supply in the Alphavan. Then the system starts up and the dish on the roof seeks an ideal alignment.

Please note that this process can take up to 5-10 minutes.

Please also note that for a well-functioning Internet connection of the Starlink system, no buildings, trees or other objects must obstruct the dish's direct view of the satellites in orbit. Starlink offers an app to check your current location.

Important note: The Starlink connector on the driver's seat is designed in such a way that the system is used when the driver's seat is rotated backwards into the living area. Please make sure that the cable is not connected when rotating the driver's seat or when

adjusting the driver's seat lengthwise (facing forward). Otherwise, there is a risk of damage and the plug/cable could be torn off.

Important note: the Starlink system in the Alphavan is not approved for use while the vehicle is in motion. Please always remove the satellite dish when starting or moving the vehicle. Otherwise, there is a great risk of damage and injury. As a customer, you are responsible for making the vehicle roadworthy before starting the journey and, in particular for dismantling the dish on the roof.

Optionally available Display Mount for Rear Seating Area

On request, the Alphavan can be equipped with a VESA display mount on the 2-seater bench seat in the living area. This makes it possible to turn the seating area into a mobile office. With the 230V connection available in the storage compartment, the monitor and peripheral devices can be supplied with electricity and with a rotated driver's seat an office workplace is created.

Important note: Please note that the monitor mount is not approved for use while driving. There is a risk of injury. Please make sure to disassemble the display holder when moving the vehicle.

Optionally available Goldschmitt HLC smart levelling system

On request, the Alphavan can be equipped with the "HLC smart" levelling system from Goldschmitt. This system allows the vehicle to be levelled by means of an integrated sensor.

Operation is carried out either via the remote control included with delivery or alternatively via a smartphone app via Bluetooth, which can be downloaded and installed in the common app stores. Please refer to the manufacturer's operating instructions for both systems, especially for the first pairing of the system with the Bluetooth app.

To pair the system with the Bluetooth app, the smartphone app must be started and the visible Bluetooth system must be connected when the ignition is active / the engine is started and the levelling system aligns itself after engine start.

Both operating mechanisms allow both automatic levelling and manual levelling of the vehicle. Please refer to the original user manuals for more information.

Note: When starting the engine in the Alphavan, the levelling system is also activated – this can be heard by an active pressure system.

Note: Due to the shorter support length on the rear axle, it is recommended that the rear is always positioned on the higher side when there is a slope so that the larger stroke on the front axle can be fully utilised.

Note: With the standard raised chassis of the Mercedes-Benz Sprinter with all-wheel drive, the available stroke is limited, especially at the rear axle, due to the installation situation and the space available there. It may therefore be necessary to use additional shims to raise and level the vehicle/wheels with sufficient stroke. In this case, place suitable pads directly under the relevant plates of the system and pay attention to a stable and straight installation surface.

Important note: the system is equipped with a mechanical emergency release. This is activated via a switch "HLC NOT" in the FlexPort (located under the cover panel in the electronics center of the FlexPort). If the vehicle is standing on extended plates and the supports can no longer be retracted electrically, this mechanism unlocks the valves of the system and the dead weight of the Alphavan pushes the supports back. In order to fully retract the supports in this case, however, it must be supported with a suitable lever tool / jack. By default, the "HLC NOT" switch is set to 0 = OFF. To activate the emergency release, please set the switch to 1.

Note: If the emergency release is activated, the engine of the vehicle is started and then the system is retracted and the vehicle is turned off again, the system will emit a "beep" for several minutes to signal that the emergency release is still active.

In addition, the lifting support system is equipped with a reset switch "HLC RESET" (housed under the cover panel in the electronics center of the FlexPort). This switch can be used to reset the entire system in the event of a malfunction. Please note that in the normal state, the switch "HLC RESET" must be set to 1. To

perform a reset, the switch must be switched to 0 for a short time and then back to 1!

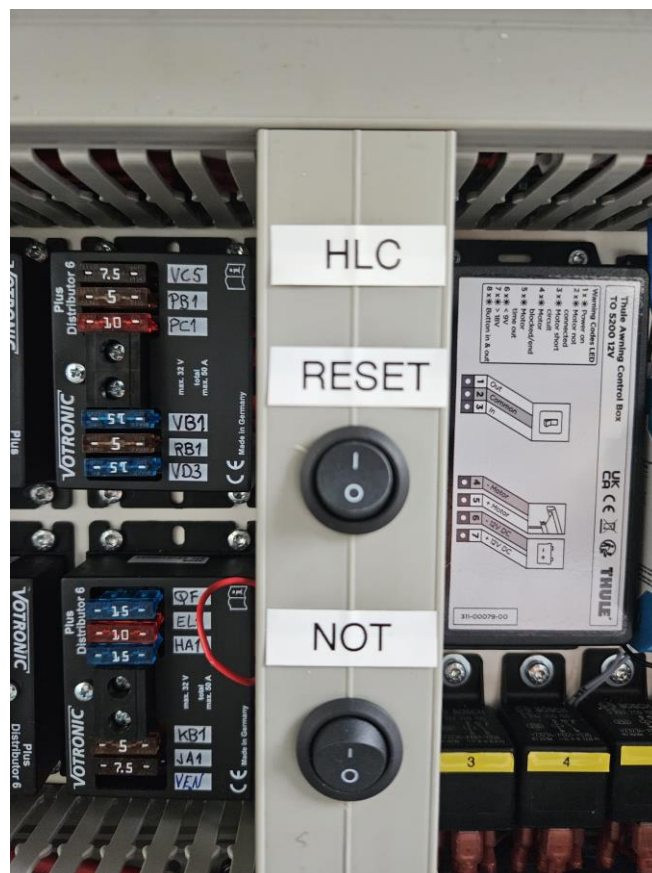

Important note: If the lifting support system is extended, at least the wheels on the rear axle are probably still in contact with the ground. Please make sure to retract the lifting support system if you want to move the vehicle. There is a risk of injury and damage in case of non-compliance!

Mercedes-Benz Information and Systems

Service, maintenance, and repair

Mercedes-Benz has a very dense service network with over 4,300 Mercedes-Benz branches and authorised service partners. That is why you can make use of the normal and proven Mercedes-Benz service in the event of problems relating to your basic vehicle, i.e., if it is not a question of motorhome-specific systems. In addition, the "MobiloVan" insurance guarantees up to 30 years of mobility with regular maintenance of the vehicle by an authorized service partner.

Mercedes-Benz MobiloVan

With "MobiloVan", Mercedes-Benz guarantees up to 30 years of mobility with regular maintenance of the vehicle by an authorised service partner. The following services are offered by MobiloVan in Europe:

 Fahrtkosten für die An- / Abfahrt des Technikers zum / vom Pannort	 Fahrzeug-Bringservice im Umkreis von 50 km des Mercedes-Benz Service-Partners
 Hilfe vor Ort bei Kleinreparaturen bis zu 150 € inkl. MwSt.	 Ersatzfahrzeug für die Dauer der Reparatur (bis zu 3 Werktag)
 Abschleppen zum nächstgelegenen autorisierten Mercedes-Benz Service-Partner	 Flug / Bahn (Hin- und Rückreise bis zu 400 € inkl. MwSt. pro Person)
 Taxi, Fahrservice und öffentliche Verkehrsmittel bis maximal 75 € inkl. MwSt.	 Hotel mit Frühstück für die Dauer der Reparatur bis zu 400 € inkl. MwSt. pro Person

Systems and Functions

The Alphavan is equipped with a variety of different Mercedes-Benz comfort, infotainment, and assistance systems. The exact functionality of these systems can be found in the Documentation from Mercedes-Benz or in the digital operating instructions on the MBUX. In addition, Mercedes-Benz offers an app for your smartphone, the so-called "**Mercedes-Benz Guides**" app. This can be downloaded free of charge from the iOS App Store or the Google Play Store. We recommend all customers to download this app.

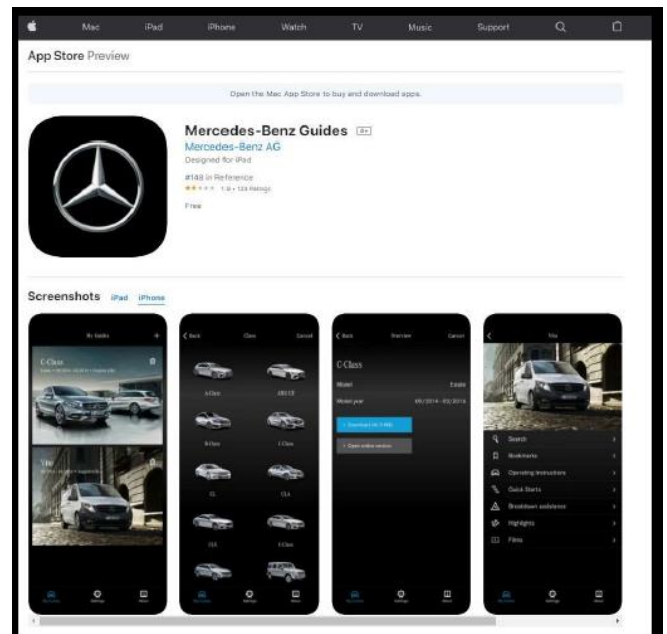

Nevertheless, we would like to describe some of the functions in a nutshell and prepare the corresponding advantages for you at this point.

Active Distance Assist Distronic

This system can maintain the distance set by the driver to the vehicle in front and support him, for example, when driving on the motorway or in stop-and-go.

The system accelerates automatically and brakes at a maximum of half the braking power to maintain the safety distance. If the system detects that stronger braking is necessary, the driver is warned visually and acoustically. In the event of a risk of a collision, Active Brake Assist also intervenes to avoid an accident as far as possible.

Active Brake Assist

Active Brake Assist can help to avoid accidents with vehicles in front and with crossing pedestrians or to mitigate the consequences of accidents. If the risk of a collision is detected, a visual and acoustic warning is first triggered. If the driver brakes, he may be supported by adaptive brake assist.

Active Crosswind Wizard

Crosswind Assist detects lane offset caused by strong crosswind gusts through brake interventions and supports the driver in keeping the lane. This is because a sudden lane shift of the

vehicle can trigger inappropriate steering reactions of the driver.



Attention Assist

The attention assistant ATTENTION ASSIST warns the driver of fatigue and microsleep. The system can contribute to road safety especially on night trips and on long journeys. Attention ASSIST is displayed on the instrument cluster between the tachometer and the speedometer. To evaluate the state of attention, the system automatically registers the driving behavior and steering movements.



High Beam Assist

High Beam Assist automatically switches the high beam on and off according to the traffic situation, thus relieving the driver of manual dimming and dimming. The system is controlled by a camera behind the windscreen, which permanently records the traffic in front of the vehicle.

Traffic Sign Assistant

The Traffic Sign Assist shows the driver detected speed limits as well as entry and overtaking bans.

This is particularly important on routes with frequently changing speed limits, for example on construction sites.



Cruise control

The Cruise Control enables relaxed and economical driving, especially on long distances. It relieves the driver by maintaining a preset speed without the driver having to operate the accelerator pedal.

Parking package with 360° camera

The parking package with 360° camera can provide the driver with all-round visibility and relieves the driver when entering and exiting the parking space as well as when manoeuvring. The 360° camera makes the area directly around the vehicle visible, also from a bird's eye view and below the window line. It helps to detect obstacles when parking and manoeuvring.

In addition, Parking Assist warns visually and acoustically of obstacles in front of and behind the vehicle up to a speed of 10 km/h and helps to prevent damage during parking and manoeuvring.



Hill start assistance

The hill start aid can make it easier to start on inclines by preventing the vehicle from rolling back. It is linked to the Electronic Stability Program ESP® and maintains the brake pressure for a few seconds after releasing the service brake on slight inclines.

Blind Spot Assist

Blind Spot Assist with Rear Cross Traffic Alert can help prevent accidents when changing lanes and reversing out of parking by means of visual and acoustic warning signals. If Blind Spot Assist detects a vehicle in the blind spot, it warns with a red triangle in the corresponding exterior mirror. If the direction indicator is set despite this visual warning, the triangle begins to flash quickly, and an acoustic warning is also output. In addition, the Rear Cross Traffic Alert can help prevent accidents when reversing out of parking by warning the driver of crossing traffic.

Lane Keeping Assist

Lane Keeping Assist can help prevent accidents caused by unintentionally leaving the lane with visual, acoustic, and haptic signals. In vehicles with rear-wheel drive, the driver is prompted by a vibration on the steering wheel to turn back. The risk of accidents due to microsleep or decreasing concentration can thus be reduced. For this purpose, a camera that can detect road boundaries monitors whether the vehicle is moving in the lane. If Lane Keeping Assist detects active driving behaviour, for example by steering, braking, accelerating, or actuating the direction indicator, the system does not issue a warning.



Burglary-theft warning system

The Burglary-Theft Warning System offers a high level of theft protection for the vehicle and cargo. The burglary and theft warning system is automatically activated when the radio remote control of the central locking system is operated. The alarm triggers as soon as one of the doors is opened or unlocked from the inside when activated. Even if the bonnet is opened or when trying to unlock a door other than the driver's door with the manual emergency key, the alarm is triggered.

An active system is indicated by the flashing red light in the roof control unit.



Multimedia system Mercedes-Benz User Experience (MBUX)

The new generation of infotainment system enables many functions, such as navigation, radio (incl. DAB), media playback, telephone, setting of vehicle systems, etc. The system can be operated via the touch screen as well as via a touch pad on the right side of the steering wheel and the intelligent

voice control "Hey Mercedes". Say "Hey Mercedes" and then say what you would like to do. Important: the Mercedes ME services need to be activated for a good overall performance.

The MBUX multimedia system with 26 cm (10.25 inch) touchscreen leaves nothing to be desired in terms of infotainment, navigation, and communication in the vehicle. The fast hard disk navigation with high-quality topographic 3D map display takes live traffic information (traffic information in real time, country-specific) into account and thus enables dynamic destination guidance, with the help of which traffic jams can be avoided and travel times shortened. Other highlights include smartphone integration via Android Auto, Apple CarPlay, or the Bluetooth® interface with hands-free function for distraction-free calls while driving.

Mercedes-Benz breakdown call

In case of a breakdown or to call for help, you can press the breakdown button in the roof control unit. A voice connection to the Mercedes-Benz Customer Center is then set up.



Mercedes-Benz emergency call system

In the event of an accident, the Mercedes-Benz emergency call system can help to significantly shorten the time until rescue workers arrive at the scene of the accident. Data transmission takes place via the communication module (LTE) for digital services in the vehicle.

The emergency call can be triggered automatically by the crash sensors or manually by the driver via the SOS button in the roof control unit.



It is then sent to the Mercedes-Benz emergency number or to a local emergency call centre. The system establishes a voice connection to the Mercedes-Benz emergency call centre or to the local emergency call centre and transmits the exact position and other information necessary for effective rescue and recovery. The Mercedes-Benz emergency call system is already activated when the vehicle is handed over. There is no need to accept a separate term of use. Please note that the Mercedes-Benz emergency call has been designed for operation while driving / engine running and not for stationary phases (e.g., if you have parked the vehicle on a camping site). The functionality could be limited in this case.

Mercedes ME connect

As a Mercedes-Benz motorhome customer, you have access to the Mercedes ME services for three years. We therefore recommend that these are activated right at the beginning. We are happy to support you in the activation process. Once activated, you can use the Mercedes ME app, which allows you to send destinations to the vehicle or check vehicle information on your smartphone. In addition, many useful services are activated in the vehicle that extend the MBUX system, such as real-time traffic information, intelligent voice control "Hey Mercedes", weather information and others.

Hibernation Mode

If you do not want to move the vehicle for a long time, it is recommended to activate the Hibernation Mode. This function puts the Alphavan into a sleep mode with a minimum energy consumption, so that the batteries are spared, and the vehicle usually starts without any problems even after a long standstill period. The function can be activated via the MBUX multimedia system.

General Recommendations for longer standstill periods

- Park the vehicle with the parking brake released and secure it against rolling away by inserting a gear (P position in vehicles with automatic transmission) or by means of a blocking device
- Remove papers and other items from the instrument panel and seats
- Open all ventilation flaps
- Raise sun visors
- Remove dirt, snow, and moisture from the interior, especially in the footwell
- Close doors, windows, bonnet, and sunroof
- Do not park the vehicle under overhead lines, overhead lines in the immediate vicinity of railway lines, trees, shrubs, masts, etc.
- Protect tyres against direct sunlight in summer
- Fully charge the vehicle battery before parking the vehicle, check it every 3 months and recharge it if necessary or charge it continuously with 0.06A
- The auxiliary battery must be connected to landline power at all times and should be fully charged at the beginning of the standstill period.
- Replenish AdBlue® according to ISO 22241, possibly remove AdBlue® adhesions with plenty of water to avoid crystallization
- Do not store the vehicle below minus 10 °C to avoid freezing the AdBlue®
- Before the start of the cold season, check the coolant and windscreen washer liquid for antifreeze and, if necessary, replace it with the prescribed coolants or windscreen cleaners

- For vehicles that are parked for more than 2 months, increase the tire pressure to about 4.7 bar (about 2 bar above normal pressure) to avoid leveling. In the case of a longer service life, check the tyre pressure every 3 months and correct it if necessary

FlexPort

In the FlexPort of the Alphavan you have plenty of storage space for your equipment and luggage. With a length of about 220cm and a width above the trunks of 170cm, you can very flexibly accommodate and load and unload things.

When the Alphavan is delivered, flexibly movable hooks are available for the attached rails. In addition, you can purchase more high-quality fastening systems at different retailers.

The FlexPort also contains the freshwater tank and the electric distributor including the living room battery. The other storage compartments can also be used freely by you.

Important note: the door of the FlexPort to the interior of the Alphavan can only be opened from the living room area and not from the FlexPort. If there are people in the FlexPort, please make sure that the door to the interior is always open for ventilation. It is also possible to completely leave the door out of the hinges for this travel purpose.

Note: The rear doors of the Mercedes-Benz Sprinter are equipped with a lever for opening the rear doors from the inside. This is located on the inside of the rear door on the passenger side. The lever might be located behind a stowed camping seat.

Safe Lashing of objects

Correct lashing of objects - especially on the available airline lashing rails or on the optionally available heavy-duty pull-out in the FlexPort - is an important prerequisite for safe travel. At this point, the lashing of a bicycle should serve as an example of various basic rules of safe lashing. In order to securely tie down such a bike, the so-called "four-point lashing" should be followed, i.e. ideally the

lashing points on the ground form a rectangle around the bicycle, which is formed with four separate lashing / tightening straps. In this case, a separate lashing / lashing strap is attached to the floor at each corner of the rectangle. The lashing points should be chosen as low as possible (on the loading floor and not on the side lashing rails in the FlexPort) in order to achieve optimal stability. In this way, it is possible to avoid lifting of the objects while driving. As a basic rule for the tie down force during lashing, you should tie down in such a way that, for example, the front fork deflects slightly.

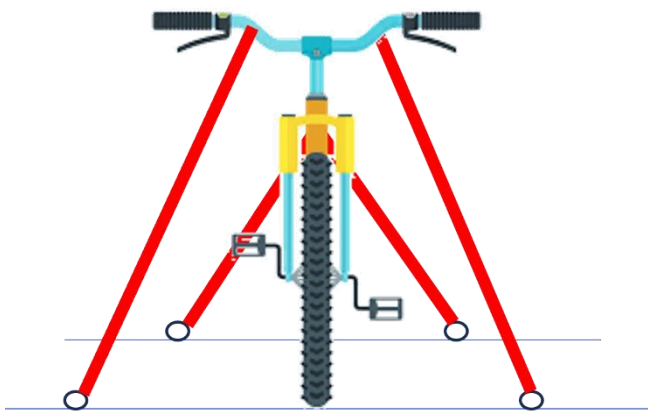

Premium Sound System

Optionally, the Alphavan can be equipped with a high-quality sound system. You will find helpful information about this system in this section.

The sound system has two sound modes: "Driving" and "Living area". In "Driving" mode, the sound output of the Mercedes MBUX infotainment system always has priority and is output on the speakers. If, for example, you want to play music from your smartphone in this mode, please connect it via Bluetooth to the MBUX and not to the sound system "JEHNERT BT". If the sound system in your vehicle is controlled via the MBAC, the "Driving" mode is automatically activated when you start to drive.

Please note that when changing the modes by switching the softkey "Living Area" on and off, the soundsystem must be restarted and therefore limited sound output works for about 5-10 seconds on only

a part of the speakers. Extensive tests have also shown that the activation of the sound mode "Living Area" sometimes must be carried out repeatedly and in some cases has deactivated itself again. In this case, please simply switch on the mode again.

In the "living area" mode, either a smartphone can be connected to the sound system via Bluetooth or the TV. Please note that in this mode both sources are really connected in parallel. So if you have both the TV activated and play Bluetooth audio, you will probably hear both sources overlaid. In this case, either stop the Bluetooth audio or set the volume of the TV to silent. Please also note that in "Living Area" mode, the MBUX has no audio priority. This means that you will not hear audio if you are paired with the MBUX via Bluetooth with your smartphone and, for example, answer an incoming call. We therefore recommend that you either turn off the MBUX in this case or disconnect the Bluetooth connection with the MBUX.

A peculiarity of the Mercedes-Benz infotainment system is the loudspeaker architecture. When using the sound system, it cannot be avoided that in the "living area" mode, the MBUX outputs audio on the center speaker (behind the windshield in the middle of the dashboard). Therefore, it is recommended that in the "LivingArea" mode, the volume of the MBUX is always set to silent or the MBUX is completely switched off.

If you want to connect to the sound system in the "living area" mode with the smartphone, please search for the Bluetooth receiver of the system in the Bluetooth menu. This is visible as "**BTR200**", "**JEHNERT BT**" or as "**Jehnert Sound**". Please note that you can only connect one device to this Bluetooth receiver at a time. So, if you are already connected to a smartphone and want to connect with another smartphone, the Bluetooth connection of the first smartphone must first be disconnected (either turn off Bluetooth completely or actively disconnect the connection to the Sound System in the Bluetooth settings).

Please also note that the Bluetooth receiver of the sound system is only visible when the "Living Area" mode is switched on.

Note: it has been shown in various tests and also in customer use that there are devices that have a Bluetooth connection and whose activated Bluetooth can interfere with the signal of the built-in sound system. It is therefore recommended to deactivate the Bluetooth activity of all active Bluetooth devices in the vehicle (e.g. Bluetooth mouse, Bluetooth notebook, etc.).

Note: Different Bluetooth devices (e.g. smartphones or tablets) nowadays support the parallel connection to several Bluetooth audio devices. If you have problems with the audio output on the sound system in the Alphavan, first disconnect all active connections to the other devices to ensure that other Bluetooth connections from the same device do not interfere with the audio output on the Premium Sound System.

Important note: the Bluetooth volume of the sound system is standardized. The volume can be adjusted up and down via corresponding buttons on the smartphone. However, please note that in various smartphones there is a function to limit this output volume. This may mean that you will never be able to adjust the Bluetooth volume to an optimal volume for the sound system. A corresponding setting can normally be found in the settings menu of the smartphone (e.g. on the iPhone under "Settings" → "Sounds and haptics" "Headphone safety" → "Reduce loud sounds"). Special applications on smartphones or smart watches can also cause the audio output on a Bluetooth sound system to be corrected downwards. Please always ensure that this is not the case when you encounter problems with the Sound System in the Alphavan.

Please also note that if you are connected to the sound system via Bluetooth, the audio of incoming calls will also be played on the system, while you will not have the opportunity to speak. For

incoming calls, ideally briefly disconnect the Bluetooth connection to the sound system.

The sound system can also be controlled via the MBUX. In the menu Vehicle you will find the entry "Sound system". In this menu you can switch on the mode "Living area". If this is not active, the "Drive" mode with audio priority of the MBUX is automatically active. In "Living Area" mode, the overall volume of the system can be set via the "LEVEL" softkey. At level 0, the volume is silent. In "Drive" mode, the volume is controlled on the MBUX itself and not via this softkey. An operation of the visible softkey has no effect in this case.

Via the softkey "Bass" the bass portion of the sound system can be varied in both modes "Living area" and "Driving".



Optional auxiliary air suspension system on rear axle

Optionally, the Alphavan can be equipped with an additional air suspension system on the rear axle. In this case, please refer to the manufacturer's operating instructions, which are enclosed with the Alphavan upon delivery.

Appendix 1 – Energy Consumption with Active 230V Consumers

In this section, you will receive a table with real data that the Alphavan team has measured out in their own tests. The individual descriptions thus give a realistic picture of the actual energy consumption – but deviations are basically possible.

The tests are based on the Li-ion battery from SuperB with a capacity of 210Ah.

We use a Triple Charger from Votronic, which has the following capabilities:

- When the engine is running, the Li-ion battery is charged with up to 60Ah. This means in particular: if the vehicle is moved (or idling), then the battery level is increased by about 29% in one hour (if no other electrical consumers are active and consuming energy)
- The solar system feeds the battery with the available solar power. With the 120Wp system you can assume on a very good / sunny day with good orientation that about 30Ah will be fed back (about 14%)

Air conditioning: the air conditioning has different modes, one a cooling mode and a recirculating air operation. In recirculation mode, the energy consumption is very low. That is why we recommend to our customers that the cooling mode is first activated for about 10 minutes to cool down the vehicle before switching to energy-saving recirculation mode. The 10 minutes are enough to cool down the vehicle, because the Alphavan has very good insulation.

Induction cooker with two plates (large / small): Basically, you can use the induction cooker as usual in your home. The speed, for example, for boiling water is very similar. However, if you only want to boil water or, for example, want to make coffee, you could also do this alternatively via special devices: the voltage converter in the Alphavan also works when it is self-sufficient without landline power. This means that you have 230V on all sockets. So, if it's just about making coffee, then

you could, for example, simply operate a coffee machine or a kettle at the 230V socket in the kitchen or at the table.

Both plates of the cooker have 12 heating levels. From a subjective point of view, level 11 is just as "strong" in cooking as level 12, but the energy consumption is significantly lower in stage 11. Therefore, we recommend that cooking is done at a maximum of level 11.

The small plate needs about 5.5% of the battery capacity at level 11 with 10 minutes of cooking.

The large plate needs about 10% of the battery capacity at level 11 with 10 minutes of cooking.

For increased cooking, it would be a good idea in this case to take a portable small gas cooker with you. Otherwise, of course, electricity can also be supplied via a corresponding generator.

Refrigerator Dometic RC 10.4T 90: The energy requirement of the 90l refrigerator is on average about 37.5Ah in 24h runtime, so about 1 to 8% of the battery capacity. On particularly hot days, this value can of course also deviate upwards.

The other consumers light and in particular Of course, 230V sockets depend on the power that is called up and the actual application scenario.

ALPHAVAN Verbrauchstabelle



DOMETIC SINEPOWER DSP 2312T

Wirkungsgrad

Super B Lithium Ionen Batterie

Faktor 12V -> 230V

2300 W

89%

210 Ah

21,5

DC	WATT	60 min	% Batterie	10 min	% Batterie
1 A	230 W	21,5 Ah	10%	3,6 Ah	1,7%
1,2 A	276 W	25,8 Ah	12%	4,3 Ah	2,1%
1,4 A	322 W	30,1 Ah	14%	5,0 Ah	2,4%
1,6 A	368 W	34,5 Ah	16%	5,7 Ah	2,7%
1,8 A	414 W	38,8 Ah	18%	6,5 Ah	3,1%
2 A	460 W	43,1 Ah	21%	7,2 Ah	3,4%
2,2 A	506 W	47,4 Ah	23%	7,9 Ah	3,8%
2,4 A	552 W	51,7 Ah	25%	8,6 Ah	4,1%
2,6 A	598 W	56,0 Ah	27%	9,3 Ah	4,4%
2,8 A	644 W	60,3 Ah	29%	10,0 Ah	4,8%
3 A	690 W	64,6 Ah	31%	10,8 Ah	5,1%
3,2 A	736 W	68,9 Ah	33%	11,5 Ah	5,5%
3,4 A	782 W	73,2 Ah	35%	12,2 Ah	5,8%
3,6 A	828 W	77,5 Ah	37%	12,9 Ah	6,2%
3,8 A	874 W	81,8 Ah	39%	13,6 Ah	6,5%
4 A	920 W	86,1 Ah	41%	14,4 Ah	6,8%
4,2 A	966 W	90,4 Ah	43%	15,1 Ah	7,2%
4,4 A	1012 W	94,8 Ah	45%	15,8 Ah	7,5%
4,6 A	1058 W	99,1 Ah	47%	16,5 Ah	7,9%
4,8 A	1104 W	103,4 Ah	49%	17,2 Ah	8,2%
5 A	1150 W	107,7 Ah	51%	17,9 Ah	8,5%
5,2 A	1196 W	112,0 Ah	53%	18,7 Ah	8,9%
5,4 A	1242 W	116,3 Ah	55%	19,4 Ah	9,2%
5,6 A	1288 W	120,6 Ah	57%	20,1 Ah	9,6%
5,8 A	1334 W	124,9 Ah	59%	20,8 Ah	9,9%
6 A	1380 W	129,2 Ah	62%	21,5 Ah	10,3%
6,2 A	1426 W	133,5 Ah	64%	22,3 Ah	10,6%
6,4 A	1472 W	137,8 Ah	66%	23,0 Ah	10,9%
6,6 A	1518 W	142,1 Ah	68%	23,7 Ah	11,3%
6,8 A	1564 W	146,4 Ah	70%	24,4 Ah	11,6%
7 A	1610 W	150,7 Ah	72%	25,1 Ah	12,0%
7,2 A	1656 W	155,1 Ah	74%	25,8 Ah	12,3%
7,4 A	1702 W	159,4 Ah	76%	26,6 Ah	12,6%
7,6 A	1748 W	163,7 Ah	78%	27,3 Ah	13,0%
7,8 A	1794 W	168,0 Ah	80%	28,0 Ah	13,3%
8 A	1840 W	172,3 Ah	82%	28,7 Ah	13,7%
8,2 A	1886 W	176,6 Ah	84%	29,4 Ah	14,0%
8,4 A	1932 W	180,9 Ah	86%	30,1 Ah	14,4%
8,6 A	1978 W	185,2 Ah	88%	30,9 Ah	14,7%
8,8 A	2024 W	189,5 Ah	90%	31,6 Ah	15,0%

Appendix 2 – Placement of Fuses

Model Premium Line



** = optionale Ausstattung

Appendix 3 - Fuse Location in Model ACTIVE LINE

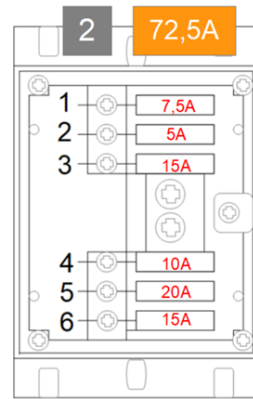
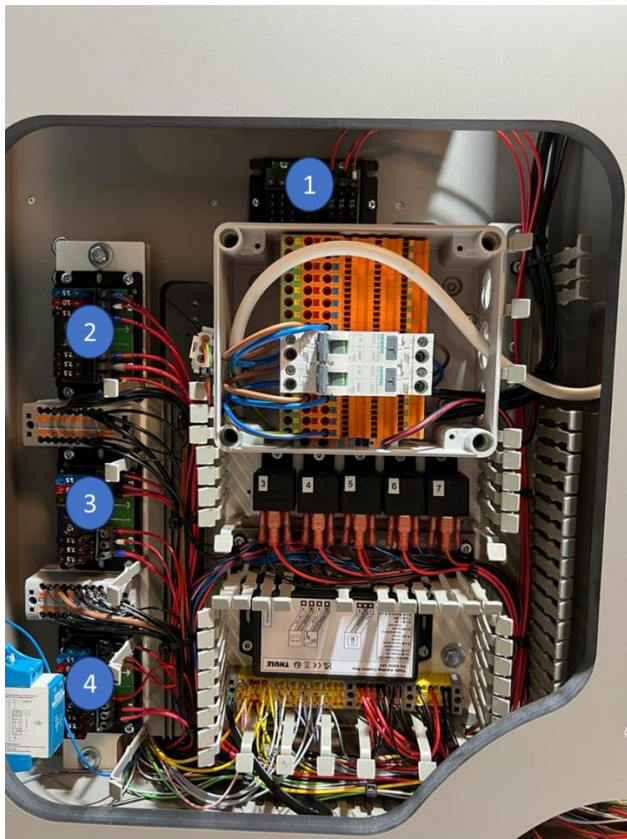

- 436 Zuleitung Schlaf
- 424 Rear Display
- 494 Kühlschrank Dometic
- 491 12V TV Schrank
- 448 Truma Heizung Combi 6D E
- 611 12V FlexPort

Fuse Bank 2

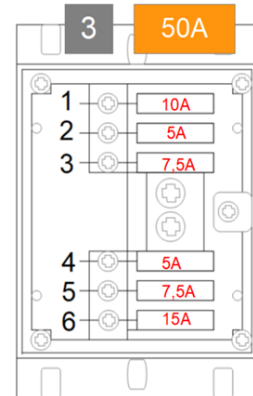

- 226 H2O Pumpe PTFIX
- 219 Ablassventil Grauwasser PTFIX
- 691 Ablassventil Frischwasser
- 466 Sitzgruppe
- 457 Grauwasser Sensor
- 306 Markise

Fuse Bank 3

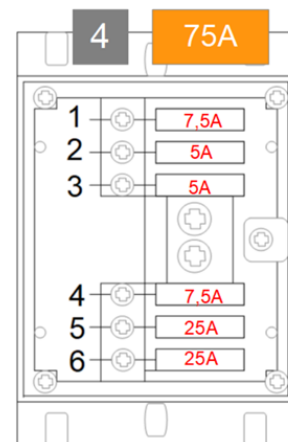

- 590 Bad Verteiler
- 552 Super B
- 21 Truma CP Plus Panel
- 268 MBAC 1-1
- 264 MBAC 1-2
- 266 MBAC 4-1

Fuse Bank 4

Fuse Bank 1

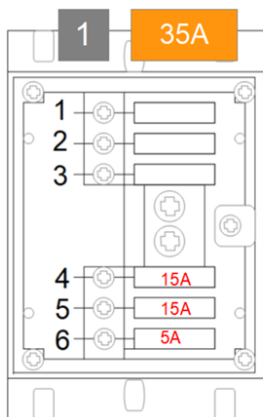

- 676 Frischwasser Heizung
- 675 Frischwasser Heizung
- 672 Frischwasser Sensor

Fuse Bank 1

Fuse Bank 2

Appendix 4 – Alphavan-specific fuse assignment in the driver's seat box

54 = Step sliding door

53 = F20-1 – Auxiliary Air Spring Goldschmitt

52= F10 – 1 – Auxiliary Air Spring Goldschmitt

51 = Driver's door step

50 = step passenger door

Appendix 5 – Emergency vests regulation and mandatory in Europe



WARNWESTENPFLICHT IN EUROPA

T Tragepflicht **M** Mitführipflicht

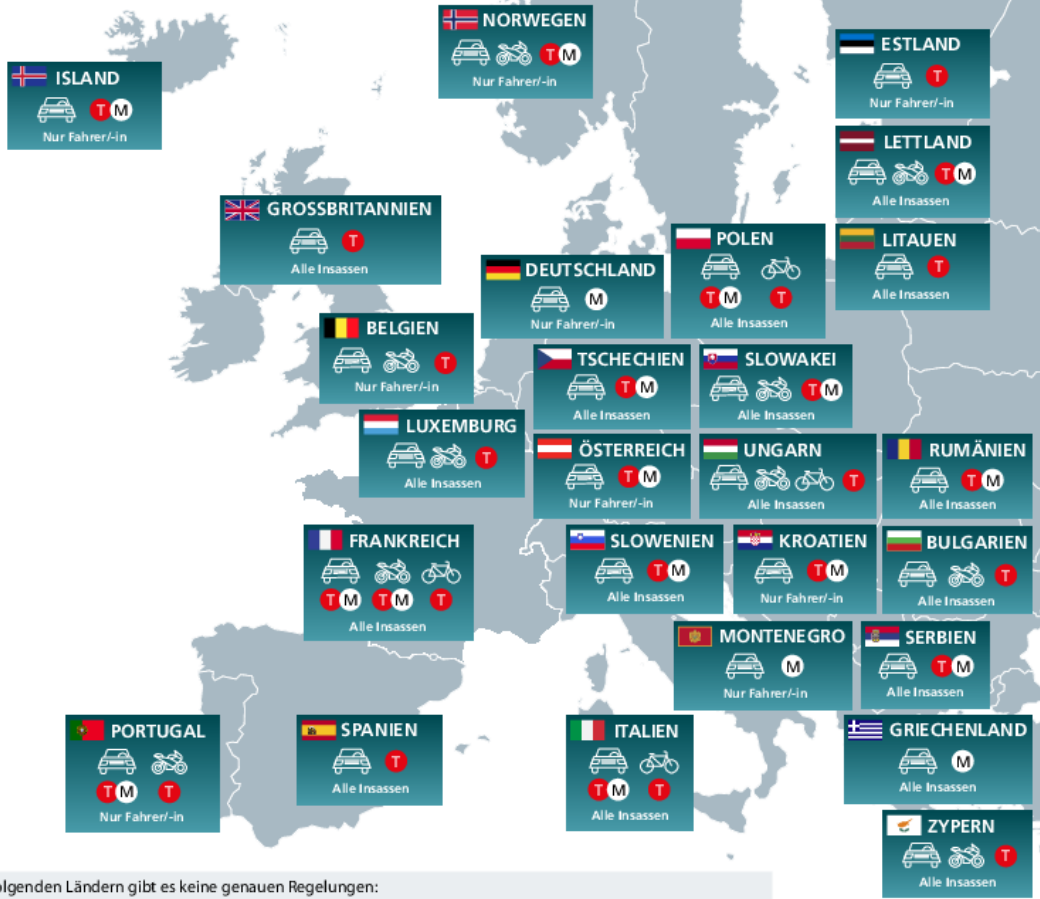

In folgenden Ländern gibt es keine genauen Regelungen:

- 🇩🇰 DÄNEMARK
 🇮🇪 IRLAND
 🇳🇱 NIEDERLANDE
 🇸🇪 SCHWEDEN
 🇨🇭 SCHWEIZ

BESONDERHEITEN

BELGIEN: Das bloße Nichtmitführen der Warnweste wird nicht bestraft.

DÄNEMARK: Das Tragen wird lediglich empfohlen.

FINNLAND: Tragepflicht für alle Personen auf der Fahrbahn, Tag und Nacht.

FRANKREICH: Die Weste muss vor dem Verlassen des Fahrzeuges angelegt werden. Gilt nachts außerorts oder bei witterungsbedingten schlechten Sichtverhältnissen auch für Radfahrende.

ITALIEN: Tragepflicht für alle, die das Fahrzeug verlassen, auf dem Fahrrad nur nachts außerhalb geschlossener Ortschaften und in Tunnel.

LUXEMBURG: Auf der Autobahn und auf Schnellstraßen, auch für Zufußgehende, die nachts oder tagsüber bei schlechten Sichtverhältnissen entlang der Straße gehen.

MONTENEGRO: Muss sichtbar über die Rückenlehne gehängt werden.

NORWEGEN: Ausländische Fahrende sind nur dann betroffen, wenn sie ein in Norwegen zugelassenes Kfz führen (z.B. Mietwagen).

ÖSTERREICH: Auf der Autobahn/Landstraße, gilt für Lenkender aller mehrspurigen Kraftfahrzeuge (also auch Quads, Microcars, Zugmaschinen, usw), muss vor dem Aussteigen angelegt sein.

POLEN: Zufußgehende und Radfahrende bei Dunkelheit außerorts.

PORTUGAL: Gilt für ausländische Fahrende nur, wenn sie ein in Portugal zugelassenes Kfz führen (z.B. Mietwagen).

RUMÄNIEN: Fahrende von Fahrzeugen mit einem zulässigen Gesamtgewicht von über 3,5 t.

SLOWENIEN: Auf Autobahnen oder Schnellstraßen.

SPANIEN: Warnweste muss griffbereit sein.

UNGARN: Alle Verkehrsteilnehmenden (auch auf dem Rad oder zu Fuß), die sich bei Nacht oder schlechter Sicht außerhalb geschlossener Ortschaften auf der Straße aufhalten, müssen eine Warnweste tragen.



Quelle: ACE Auto Club Europa | Juli 2022
Alle Angaben ohne Gewähr



ALPHAVAN

My Way.

Editor/Publisher:

Alphavan GmbH
Ebneststraße 31
Germany - 88239 Wangen im Allgäu
www.alphavan.de

The publisher assumes no responsibility for the completeness and correctness of this manual and reserves the right to make changes and errors. Duplication and publication of this publication, even in extracts, only with the explicit permission of the publisher.

© 2024 All rights reserved